

Fold

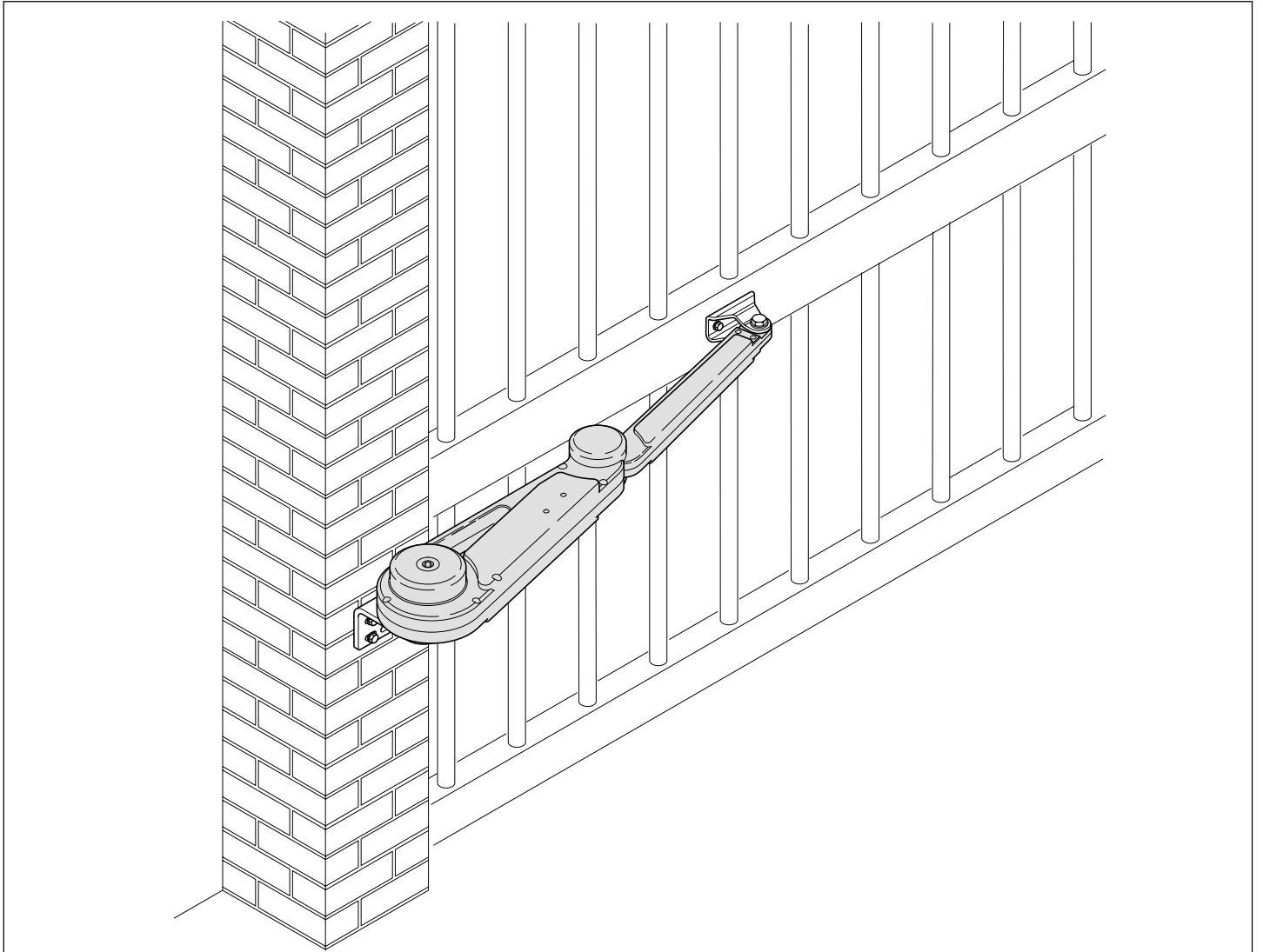

GENIUS[®]

**COMPANY
WITH QUALITY SYSTEM
CERTIFIED BY DNV
=ISO 9001/2000=**

CE

AVVERTENZE PER L'INSTALLATORE

OBBLIGHI GENERALI PER LA SICUREZZA

- ATTENZIONE! È importante per la sicurezza delle persone seguire attentamente tutta l'istruzione. Una errata installazione o un errato uso del prodotto può portare a gravi danni alle persone.**
 - Leggere attentamente le istruzioni prima di iniziare l'installazione del prodotto.
 - I materiali dell'imballaggio (plastica, polistirolo, ecc.) non devono essere lasciati alla portata dei bambini in quanto potenziali fonti di pericolo.
 - Conservare le istruzioni per riferimenti futuri.
 - Questo prodotto è stato progettato e costruito esclusivamente per l'utilizzo indicato in questa documentazione. Qualsiasi altro utilizzo non espressamente indicato potrebbe pregiudicare l'integrità del prodotto e/o rappresentare fonte di pericolo.
 - GENIUS declina qualsiasi responsabilità derivata dall'uso improprio o diverso da quello per cui l'automatismo è destinato.
 - Non installare l'apparecchio in atmosfera esplosiva: la presenza di gas o fumi infiammabili costituisce un grave pericolo per la sicurezza.
 - Gli elementi costruttivi meccanici devono essere in accordo con quanto stabilito dalle Norme EN 12604 e EN 12605.
Per i Paesi extra-CEE, oltre ai riferimenti normativi nazionali, per ottenere un livello di sicurezza adeguato, devono essere seguite le Norme sopra riportate.
 - GENIUS non è responsabile dell'inosservanza della Buona Tecnica nella costruzione delle chiusure da motorizzare, nonché delle deformazioni che dovessero intervenire nell'utilizzo.
 - L'installazione deve essere effettuata nell'osservanza delle Norme EN 12453 e EN 12445. Il livello di sicurezza dell'automazione deve essere C+D.
 - Prima di effettuare qualsiasi intervento sull'impianto, togliere l'alimentazione elettrica e scollegare le batterie.
 - Prevedere sulla rete di alimentazione dell'automazione un interruttore onnipolare con distanza d'apertura dei contatti uguale o superiore a 3 mm. È consigliabile l'uso di un magnetotermico da 6A con interruzione onnipolare.
 - Verificare che a monte dell'impianto vi sia un interruttore differenziale con soglia da 0,03 A.
 - Verificare che l'impianto di terra sia realizzato a regola d'arte e collegarvi le parti metalliche della chiusura.
 - L'automazione dispone di una sicurezza intrinseca antischiacciamento costituita da un controllo di coppia. E' comunque necessario verificarne la soglia di intervento secondo quanto previsto dalle Norme indicate al punto 10.
 - I dispositivi di sicurezza (norma EN 12978) permettono di proteggere eventuali aree di pericolo da **Rischi meccanici di movimento**, come ad Es. schiacciamento, coinvolgimento, cesoimento.
 - Per ogni impianto è consigliato l'utilizzo di almeno una segnalazione luminosa nonché di un cartello di segnalazione fissato adeguatamente sulla struttura dell'infixo, oltre ai dispositivi citati al punto "16".
 - GENIUS declina ogni responsabilità ai fini della sicurezza e del buon funzionamento dell'automazione, in caso vengano utilizzati componenti dell'impianto non di produzione GENIUS.
 - Per la manutenzione utilizzare esclusivamente parti originali GENIUS.
 - Non eseguire alcuna modifica sui componenti facenti parte del sistema d'automazione.
 - L'installatore deve fornire tutte le informazioni relative al funzionamento manuale del sistema in caso di emergenza e consegnare all'Utente utilizzatore dell'impianto il libretto d'avvertenze allegato al prodotto.
 - Non permettere ai bambini o persone di sostare nelle vicinanze del prodotto durante il funzionamento.
 - Tenere fuori dalla portata dei bambini radiocomandi o qualsiasi altro datore di impulso, per evitare che l'automazione possa essere azionata involontariamente.
 - Il transito tra le ante deve avvenire solo a cancello completamente aperto.
 - L'Utente utilizzatore deve astenersi da qualsiasi tentativo di riparazione o d'intervento diretto e rivolgersi solo a personale qualificato.
 - Non mettere in corto circuito i poli delle batterie e non tentare di ricaricarle con alimentatori diversi dalle schede Master o Slave.
 - Non gettare le batterie esauste nei rifiuti ma smaltirle utilizzando gli appositi contenitori per consentirne il riciclaggio. I costi di smaltimento sono già stati pagati dalla casa costruttrice.
- 28) Tutto quello che non è previsto espressamente in queste istruzioni non è permesso**

IMPORTANT NOTICE FOR THE INSTALLER

GENERAL SAFETY REGULATIONS

- ATTENTION! To ensure the safety of people, it is important that you read all the following instructions. Incorrect installation or incorrect use of the product could cause serious harm to people.**
- Carefully read the instructions before beginning to install the product.
- Do not leave packing materials (plastic, polystyrene, etc.) within reach of children as such materials are potential sources of danger.
- Store these instructions for future reference.
- This product was designed and built strictly for the use indicated in this documentation. Any other use, not expressly indicated here, could compromise the good condition/operation of the product and/or be a source of danger.
- GENIUS declines all liability caused by improper use or use other than that for which the automated system was intended.
- Do not install the equipment in an explosive atmosphere: the presence of inflammable gas or fumes is a serious danger to safety.
- The mechanical parts must conform to the provisions of Standards EN 12604 and EN 12605. For non-EU countries, to obtain an adequate level of safety, the Standards mentioned above must be observed, in addition to national legal regulations.
- GENIUS is not responsible for failure to observe Good Technique in the construction of the closing elements to be motorised, or for any deformation that may occur during use.
- The installation must conform to Standards EN 12453 and EN 12445. The safety level of the automated system must be C+D.
- Before attempting any job on the system, cut out electrical power and disconnect the batteries.
- The mains power supply of the automated system must be fitted with an all-pole switch with contact opening distance of 3mm or greater. Use of a 6A thermal breaker with all-pole circuit break is recommended.
- Make sure that a differential switch with threshold of 0.03 A is fitted upstream of the system.
- Make sure that the earthing system is perfectly constructed, and connect metal parts of the means of the closure to it.

- The automated system is supplied with an intrinsic anti-crushing safety device consisting of a torque control. Nevertheless, its tripping threshold must be checked as specified in the Standards indicated at point 10.
 - The safety devices (EN 12978 standard) protect any danger areas against **mechanical movement Risks**, such as crushing, dragging, and shearing.
 - Use of at least one indicator-light is recommended for every system, as well as a warning sign adequately secured to the frame structure, in addition to the devices mentioned at point "16".
 - GENIUS declines all liability as concerns safety and efficient operation of the automated system, if system components not produced by GENIUS are used.
 - For maintenance, strictly use original parts by GENIUS.
 - Do not in any way modify the components of the automated system.
 - The installer shall supply all information concerning manual operation of the system in case of an emergency, and shall hand over to the user the warnings handbook supplied with the product.
 - Do not allow children or adults to stay near the product while it is operating.
 - Keep remote controls or other pulse generators away from children, to prevent the automated system from being activated involuntarily.
 - Transit through the leaves is allowed only when the gate is fully open.
 - The user must not attempt any kind of repair or direct action whatever and contact qualified personnel only.
 - Do not short-circuit the poles of the batteries and do not try to recharge the batteries with power supply units other than Master or Slave cards.
 - Do not throw exhausted batteries into containers for other waste but dispose of them in the appropriate containers to enable them to be recycled. Disposal costs have already been paid for by the manufacturer.
- 28) Anything not expressly specified in these instructions is not permitted.**

CONSIGNES POUR L'INSTALLATEUR

RÈGLES DE SÉCURITÉ

- ATTENTION! Il est important, pour la sécurité des personnes, de suivre à la lettre toutes les instructions. Une installation erronée ou un usage erroné du produit peut entraîner de graves conséquences pour les personnes.**
 - Lire attentivement les instructions avant d'installer le produit.
 - Les matériaux d'emballage (matière plastique, polystyrène, etc.) ne doivent pas être laissés à la portée des enfants car ils constituent des sources potentielles de danger.
 - Conservé les instructions pour les références futures.
 - Ce produit a été conçu et construit exclusivement pour l'usage indiqué dans cette documentation. Toute autre utilisation non expressément indiquée pourrait compromettre l'intégrité du produit et/ou représenter une source de danger.
 - GENIUS décline toute responsabilité qui dériverait d'usage impropre ou différent de celui auquel l'automatisme est destiné.
 - Ne pas installer l'appareil dans une atmosphère explosive: la présence de gaz ou de fumées inflammables constitue un grave danger pour la sécurité.
 - Les composants mécaniques doivent répondre aux prescriptions des Normes EN 12604 et EN 12605.
Pour les Pays extra-CEE, l'obtention d'un niveau de sécurité approprié exige non seulement le respect des normes nationales, mais également le respect des Normes susmentionnées.
 - GENIUS n'est pas responsable du non-respect de la Bonne Technique dans la construction des fermetures à motoriser, ni des déformations qui pourraient intervenir lors de l'utilisation.
 - L'installation doit être effectuée conformément aux Normes EN 12453 et EN 12445. Le niveau de sécurité de l'automatisme doit être C+D.
 - Couper l'alimentation électrique et déconnecter la batterie avant toute intervention sur l'installation.
 - Prévoir, sur le secteur d'alimentation de l'automatisme, un interrupteur onnipolaire avec une distance d'ouverture des contacts égale ou supérieure à 3 mm. On recommande d'utiliser un magnétothermique de 6A avec interruption onnipolaire.
 - Vérifier qu'il y ait, en amont de l'installation, un interrupteur différentiel avec un seuil de 0,03 A.
 - Vérifier que la mise à terre est réalisée selon les règles de l'art et y connecter les pièces métalliques de la fermeture.
 - L'automatisme dispose d'une sécurité intrinsèque anti-écrasement, formée d'un contrôle du couple. Il est toutefois nécessaire d'en vérifier le seuil d'intervention suivant les prescriptions des Normes indiquées au point 10.
 - Les dispositifs de sécurité (norme EN 12978) permettent de protéger des zones éventuellement dangereuses contre les **Risques mécaniques du mouvement**, comme l'écrasement, l'acheminement, le cisaillement.
 - On recommande que toute installation soit dotée au moins d'une signalisation lumineuse, d'un panneau de signalisation fixé, de manière appropriée, sur la structure de la fermeture, ainsi que des dispositifs cités au point "16".
 - GENIUS décline toute responsabilité quant à la sécurité et au bon fonctionnement de l'automatisme si les composants utilisés dans l'installation n'appartiennent pas à la production GENIUS.
 - Utiliser exclusivement, pour l'entretien, des pièces GENIUS originales.
 - Ne jamais modifier les composants faisant partie du système d'automatisme.
 - L'installateur doit fournir toutes les informations relatives au fonctionnement manuel du système en cas d'urgence et remettre à l'Usager qui utilise l'installation les "Instructions pour l'Usager" fournies avec le produit.
 - Interdire aux enfants ou aux tiers de stationner près du produit durant le fonctionnement.
 - Éloigner de la portée des enfants les radiocommandes ou tout autre générateur d'impulsions, pour éviter tout actionnement involontaire de l'automatisme.
 - Le transit entre les vantaux ne doit avoir lieu que lorsque le portail est complètement ouvert.
 - L'Usager qui utilise l'installation doit éviter toute tentative de réparation ou d'intervention directe et s'adresser uniquement à un personnel qualifié.
 - Ne pas mettre en court-circuit les pôles des batteries et ne pas tenter de les recharger avec d'autres platines d'alimentation que les platines Maître ou Esclave.
 - Ne pas jeter les batteries épuisées à la poubelle, mais les éliminer dans les conteneurs spécifiques pour le recyclage. Les coûts d'élimination des déchets ont déjà été payés par le constructeur.
- 28) Tout ce qui n'est pas prévu expressément dans ces instructions est interdit.**

FOLD Automated System

These instructions apply to the following model:

FOLD

The FOLD articulated automated system automates residential swing-leaf gates with leaves of up to 1.8 m in length. It consists of non-reversing electro-mechanical articulated operators, powered by a 12Vdc battery, each coupled to a control board recharging the battery. The SLAVE equipment (required on 2-leaf gates only) is controlled by the MASTER equipment to which all accessories and pulse generators are connected. The MASTER card can be programmed and is used to set the following: function logics, work times (by self-learning) and pause times, leaf speed, and the sensitivity of the anti-crushing device.

The "toggle" lever system ensures the gate is mechanical locked when the leaves are closed. A release system enables the gate to be moved by hand in case of trouble.

The gearmotor is supplied with a mechanical limiter which protects the transmission system against damage if the leaves are struck when moving or when open.

The FOLD automated system was designed and built for controlling vehicle access. Do not use for any other purpose.

TAB. 1 TECHNICAL SPECIFICATIONS OF FOLD OPERATOR

| MODEL | FOLD |
|--|------------------------------|
| Power supply | 12Vdc |
| Rated absorbed power (W) | 48 |
| Max torque (Nm) | 17 |
| Max load-free angular velocity (°/sec) | 17 (0,4 rad/sec) |
| Use frequency (cycles/hour) | 5 |
| Consecutive cycles on charged battery | max.15 |
| Recharging time | 10' for each completed cycle |
| Type of reduction gear | epicycloid |
| Operating ambient temperature | -20 ÷ +55 °C |
| Operator weight (Kg) | 2,8 |
| Protection class | IP 44 |
| Leaf maximum length (m) | 1,80 |
| Leaf max weight (kg) | 250 |
| Operator overall dimensions LxHxD (mm) | see fig.2 |
| Length of operator power cable | 0,7 m |

1. DESCRIPTION AND TECHNICAL SPECIFICATIONS

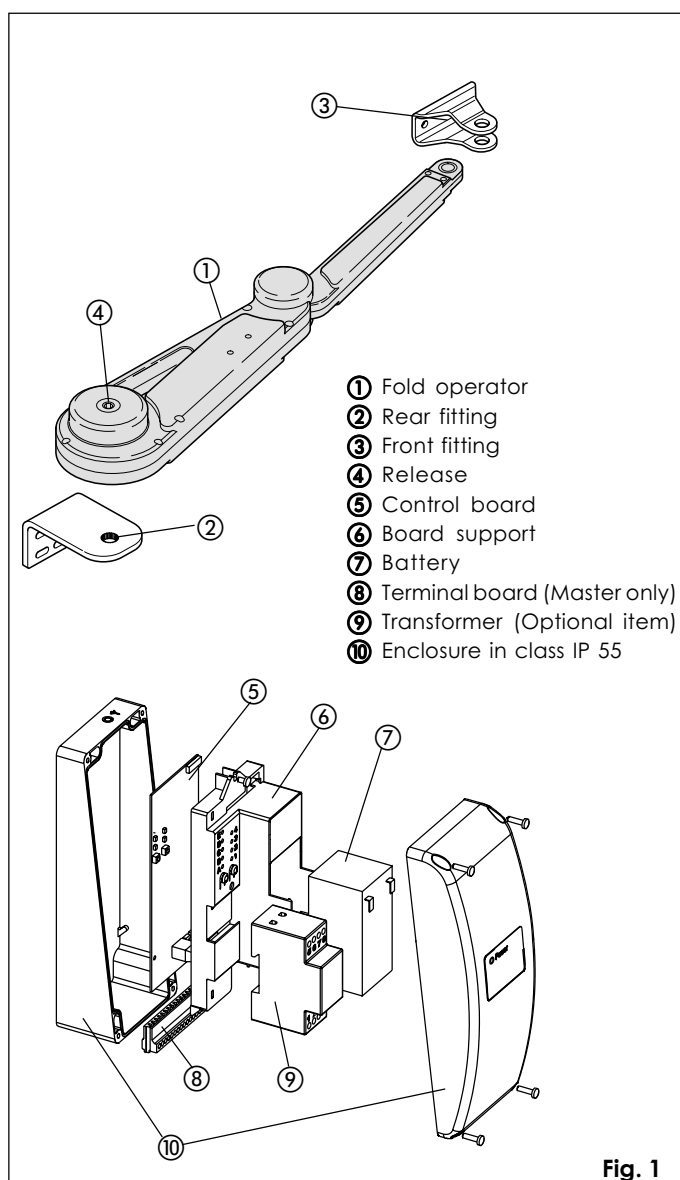

Fig. 1

2. DIMENSIONS

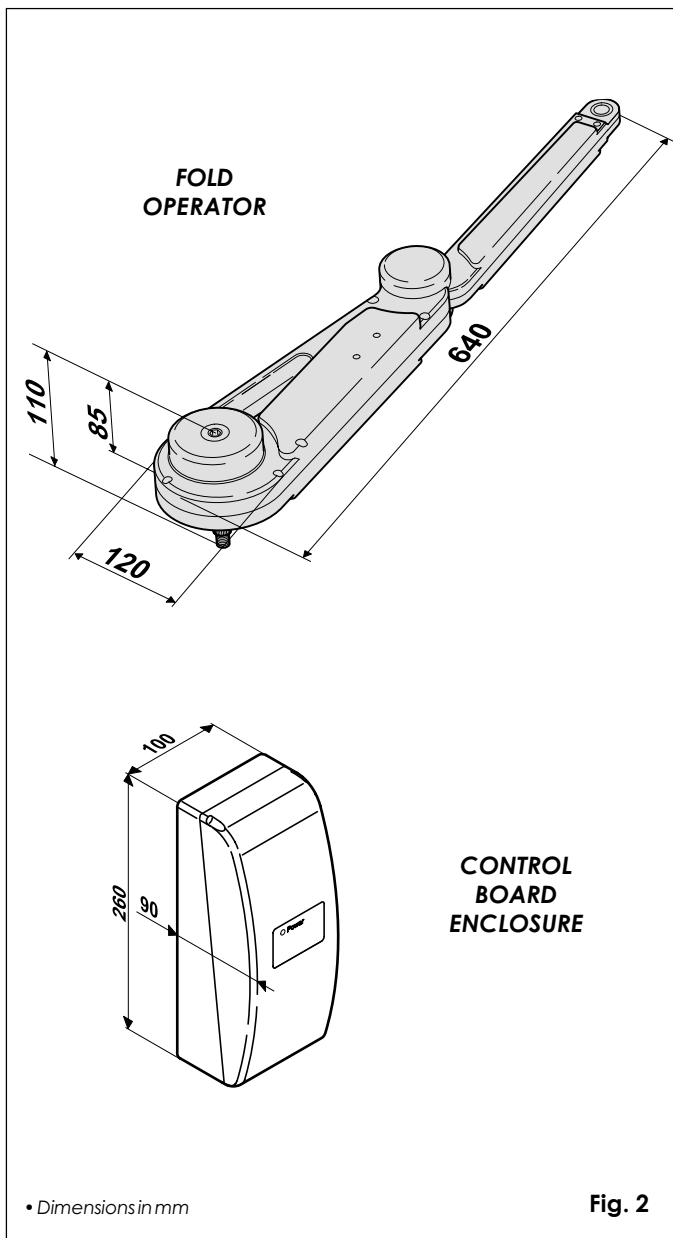
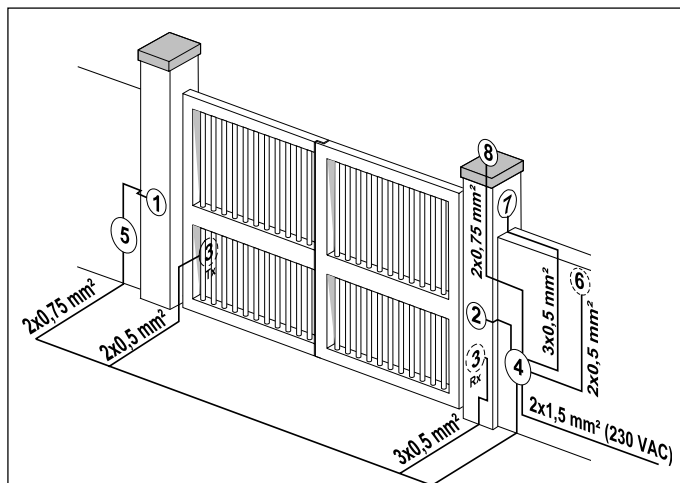

Fig. 2

3. ELECTRICAL EQUIPMENT (standard system)



- ① Left-hand Fold operator
- ② Right-hand Fold operator
- ③ Photocells
- ④ MASTER control board (controls all accessories)
- ⑤ SLAVE control board (for 2nd leaf only)
- ⑥ Key operated push-button
- ⑦ Receiver
- ⑧ 12 Vdc flashing lamp

Notes: 1) Do not extend the operator connecting cables
 2) To lay electric cables, use adequate rigid and/or flexible tubes.
 3) Always separate low voltage connection cables from those operating at 230 Vac. To prevent any interference whatever, use separate sheaths.

Fig. 3

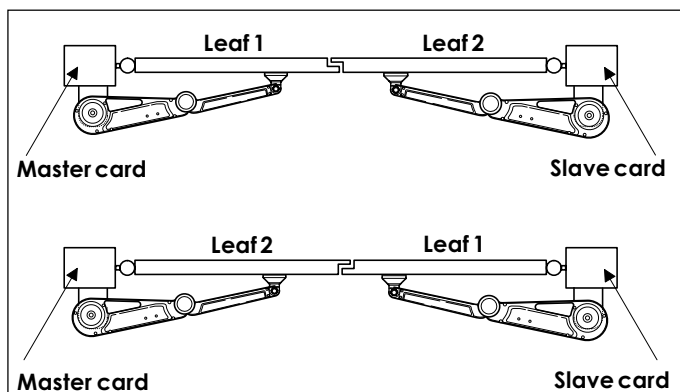

In double-leaf applications, the Master card always commands leaf 1. In case of incorrect electrical set-up, leaf 1 can be commanded by the Slave card, and leaf 2 by the Master card. For programming, refer to chapter 14. Leaf 1 is always the leaf that starts first on opening and is delayed on closing.

Fig. 4

4. INSTALLING THE AUTOMATED SYSTEM

4.1. PRELIMINARY CHECKS

To ensure safety and an efficiently operating automated system, make sure the following conditions are observed:

- The structure of the gate must be suitable for being automated. In particular, check that the structure is sufficiently

strong and rigid, and that its dimensions and weight conform to those indicated in the technical specifications.

- Make sure that the leaves move uniformly and correctly, without any irregular friction during their entire travel.
 - Make sure that the hinges are in good condition.
 - Check if the mechanical stops of the limit-switches are fitted.
- We advise you to have any metalwork carried out before the automated system is installed.

4.2. INSTALLATION DIMENSIONS

Establish the installation position of the operator by referring to Fig. 5.

Carefully check that the distance between the leaf hinge and any obstacles (wall, fencing, etc.) is greater than or equal to **minimum dimension I** referring to the selected opening angle, so that it does not interfere with the opening movement of the operator.

Fig. 5

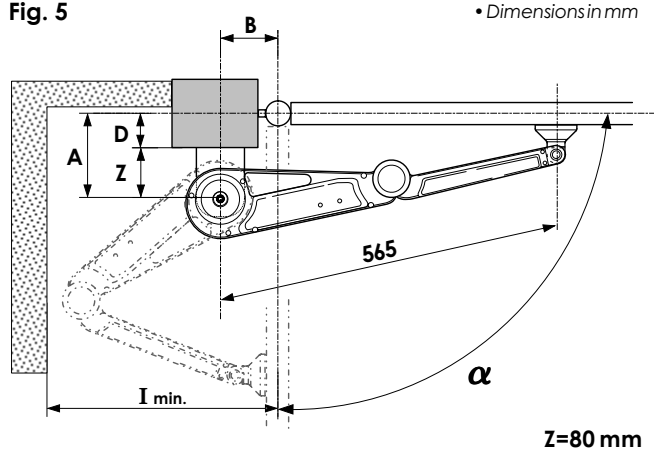

Tab. 2/a Opening at 90° (D_{max} = 205 mm)

| D | B | I min | α max |
|-----|--------|-------|-------|
| 30 | 90÷240 | ≥400 | 90° |
| 40 | 90÷240 | ≥400 | 90° |
| 60 | 90÷220 | ≥400 | 90° |
| 80 | 90÷210 | ≥400 | 90° |
| 100 | 90÷210 | ≥400 | 90° |
| 120 | 90÷180 | ≥400 | 90° |
| 140 | 90÷170 | ≥400 | 90° |
| 160 | 90÷160 | ≥400 | 90° |
| 180 | 90÷140 | ≥400 | 90° |
| 200 | 90÷100 | ≥400 | 90° |
| 205 | 90 | ≥400 | 90° |

• Dimensions in mm

Tab. 2/b Opening at 110° (D_{max} = 120 mm)

| D | B | I min | α max |
|-----|---------|-------|-------|
| 30 | 140÷250 | ≥500 | 110° |
| 40 | 140÷250 | ≥500 | 110° |
| 60 | 150÷240 | ≥500 | 110° |
| 80 | 160÷200 | ≥500 | 110° |
| 100 | 165÷180 | ≥500 | 110° |
| 120 | 165 | ≥500 | 110° |

• Dimensions in mm

4.3. INSTALLATION STEPS

The Fold operator is available in 2 versions, designed for installation according to leaf opening direction: the **Fold DX** for installation on the right (Fig.6 - RH) or the **Fold SX** for installation on the left (Fig.6 - LH).

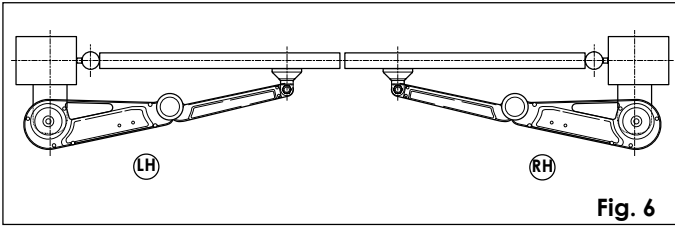

Fig. 6

- Secure the rear fitting to the pillar by welding or using suitable expansion plugs (Fig.7), observing the dimension as shown in figure 5 and checking if the fitting is perfectly horizontal.
 - ➔ The rear fitting must never be cut.
- To select the appropriate dimensions, we advise you to measure dimension D and then check if you can use a dimension B from among those indicated in Table 2/a or Table 2/b (fig.5).

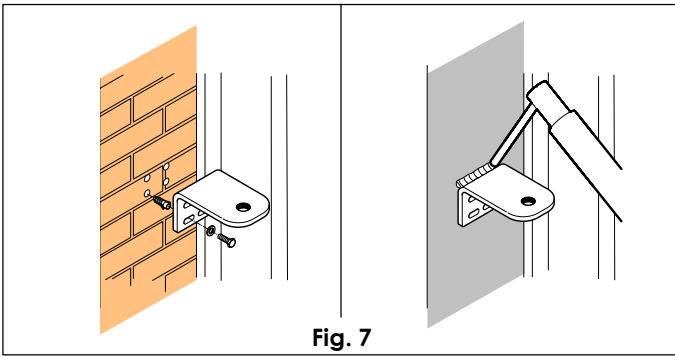

Fig. 7

- Secure the operator to the rear fitting, with the nut and washer (Fig.8), taking care fit the toothed part correctly.
 - ➔ The release plug must always face upward.

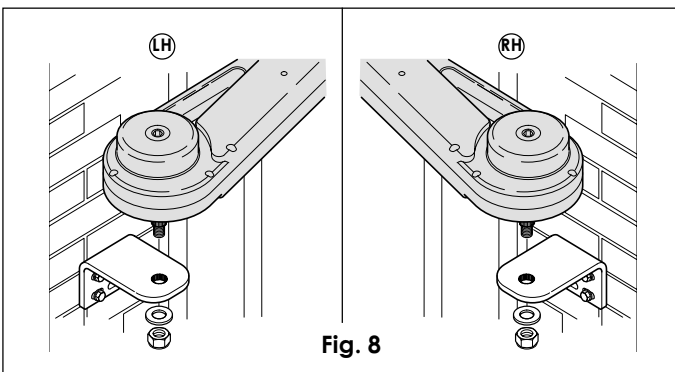

Fig. 8

- Release the operator (chapter 16).
- Take the leaf to its closed position.
- Establish the position for securing the front fitting on the leaf - take the operator (fully extended) close to the fitting, with the 3 rotation points aligned (fig.9). Check if the operator and fitting

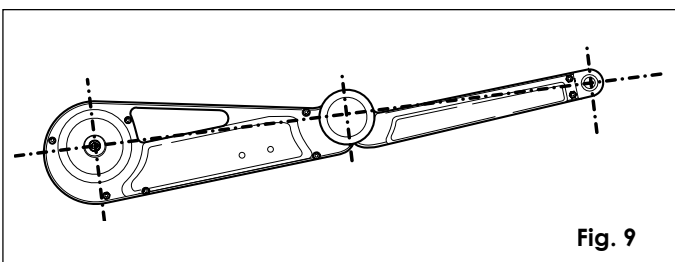

Fig. 9

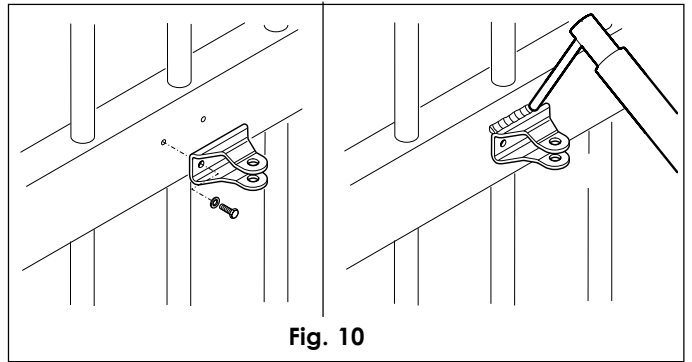

Fig. 10

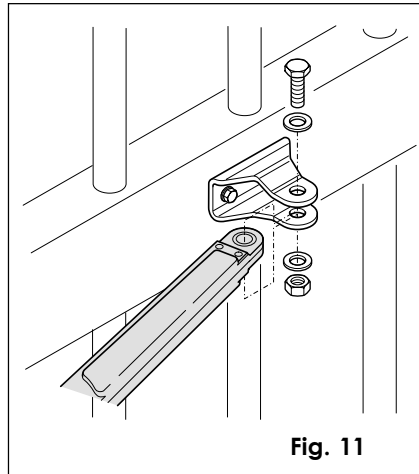

Fig. 11

- are perfectly horizontal.
- The fitting can be either welded directly to the leaf, or screwed on, using the threaded inserts (Fig. 10).
- Fasten the operator to the front fitting as shown in figure 11.
- Re-lock the operator (Chpt. 17)

MIND MASTER AND MIND SLAVE CONTROL BOARDS

5. WARNINGS

Important: Before attempting any job on the control boards (connections, maintenance), cut out electrical power and the support batteries.

- Install, upstream of the system, a differential thermal breaker with adequate tripping threshold.
- Always separate 230VAC power cable from control and safety cables (push-buttons receiver, photocells, etc.). To avoid any electrical noise, use separate sheaths or a shielded cable (with earthed shield).

6. LAY-OUT OF MASTER CARD COMPONENTS

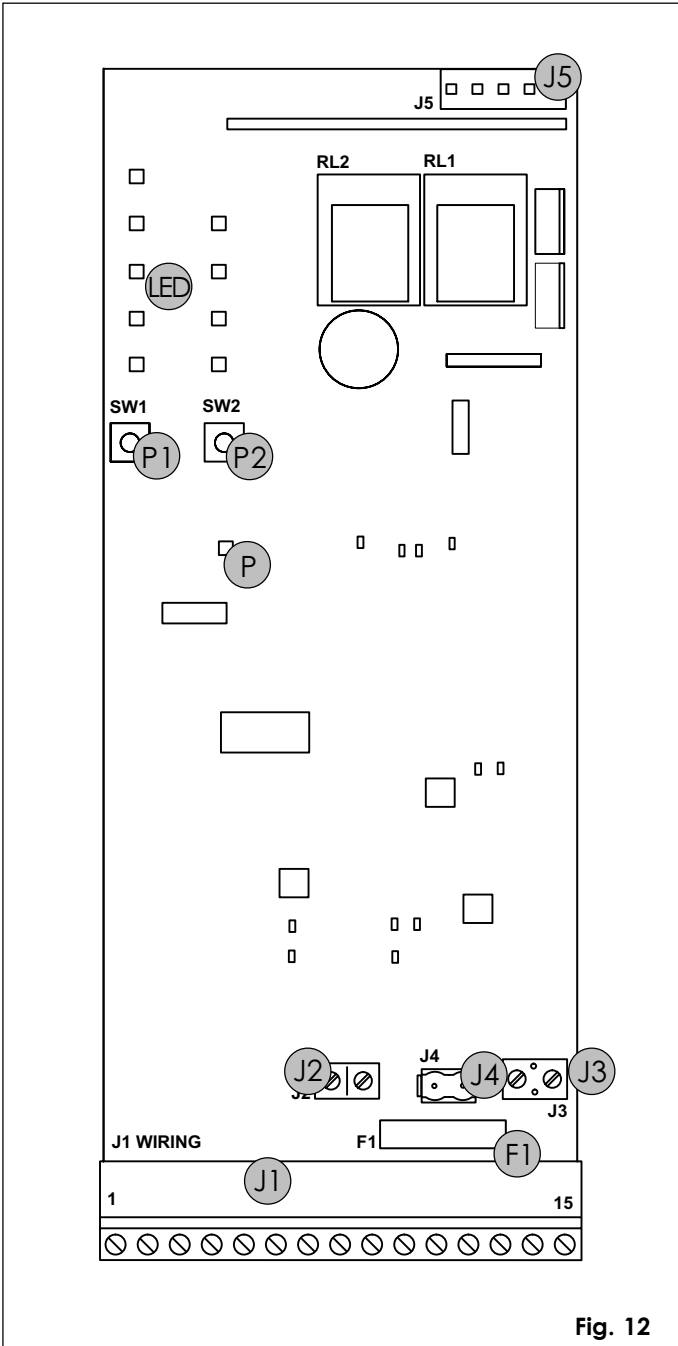

Fig. 12

7. LAY-OUT OF SLAVE CARD COMPONENTS

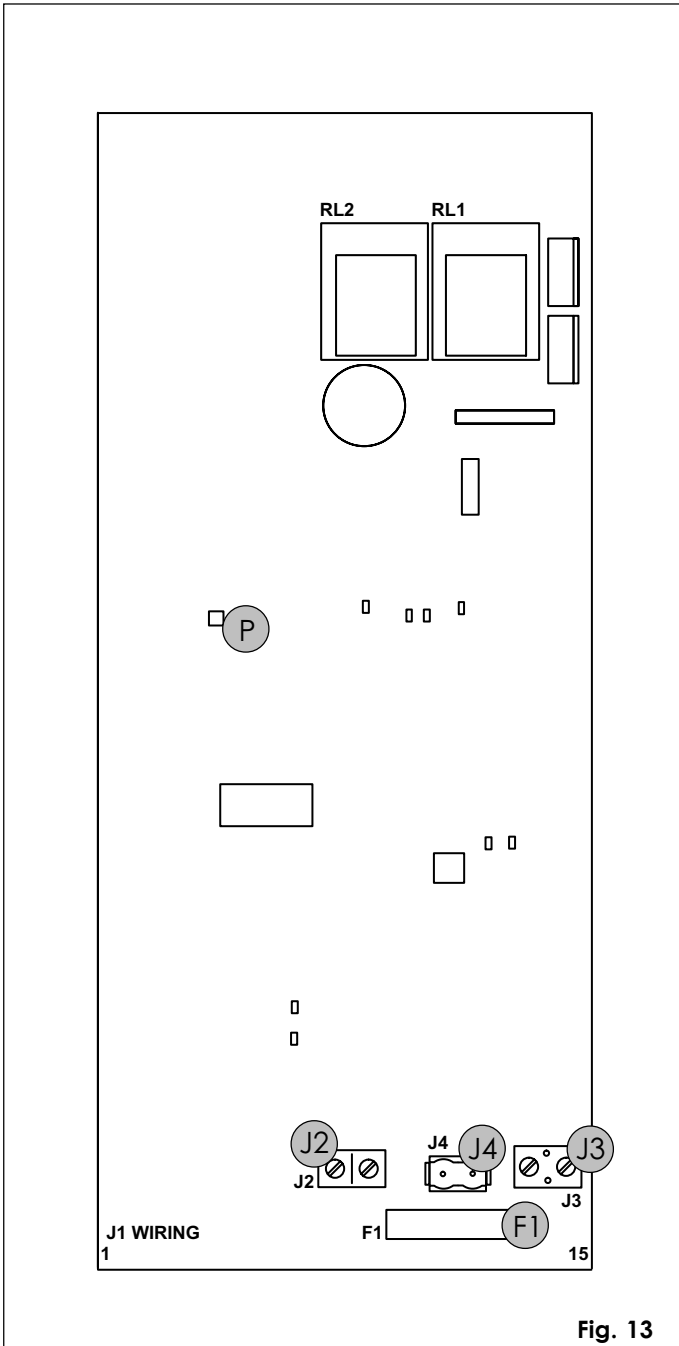

Fig. 13

| | |
|-----|------------------------------------|
| LED | Programming LEDs |
| P | Power ON and diagnostics LED |
| P1 | "Function" programming push-button |
| P2 | "Value" programming push-button |
| F1 | Battery and motor fuse - F15A |
| J1 | Accessories Terminal board |
| J2 | Transformer Terminal board |
| J3 | Motor connection terminal board |
| J4 | Battery connector |
| J5 | Minidec connector/RP Receiver |

| | |
|----|---------------------------------|
| P | Power ON and diagnostics LED |
| F1 | Battery and motor fuse - F15A |
| J2 | Bus connection terminal board |
| J3 | Motor connection terminal board |
| J4 | Battery connector |

8. MASTER AND SLAVE CARDS COMMON CHARACTERISTICS

| | |
|--------------------------------------|---|
| Batteries | hermetic Pb 12Vdc 1.2Ah - dimensions 96x46x50 |
| Enclosure protection class | IP 55 |
| Absorbed power | 16 VA |
| Motor max current | 15A |
| Operating ambient temperature | -20° +55° |
| Protection fuses | N° 1 (see fig. 12 and 13) |
| Anti-crushing function | Encoder - Current control |

9. SLAVE CARD TECHNICAL SPECIFICATIONS

| | |
|-------------------------------|-----------------------|
| Power supply | from Master |
| Terminal board outputs | Motor - Battery - Bus |

11. ELECTRIC CONNECTIONS

10. MASTER CARD TECHNICAL SPECIFICATIONS

| | |
|---|---|
| Power supply | 12Vac |
| Transformer characteristics | Primary 230 Vac - Secondary 12 Vac - 16VA |
| Accessories max. load at 24 Vdc | 150 mA |
| Rapid connector max load | 50 mA |
| Function logics | Automatic / "Stepped" Automatic / Safety device / "Stepped" semi-automatic |
| Opening/closing time | By self-learning |
| Pause time | Programmable: 5, 10, 20, 30 sec. |
| Leaf delay time when opening and closing | (op 0s, cl 0s) - (op 2s, cl 2s) - (op 2s, cl 4s) - (op 2s, cl 8s) |
| Speed | Selectable on 4 levels |
| Static force adjustment | Selectable on 4 levels |
| Terminal board inputs | Open - Open released leaf Stop - Safety devices at opng. - Safety devices at clsng. |
| Terminal board outputs | Flashing lamp - Motor - Bus - indicator-light - Accessories 24 Vdc - 12 Vdc power supply |
| Rapid connector | Minidec cards - RP cards |
| Programmable functions | Logic - pause time - leaf opening and closing delay - anti-crushing force - operators speed |

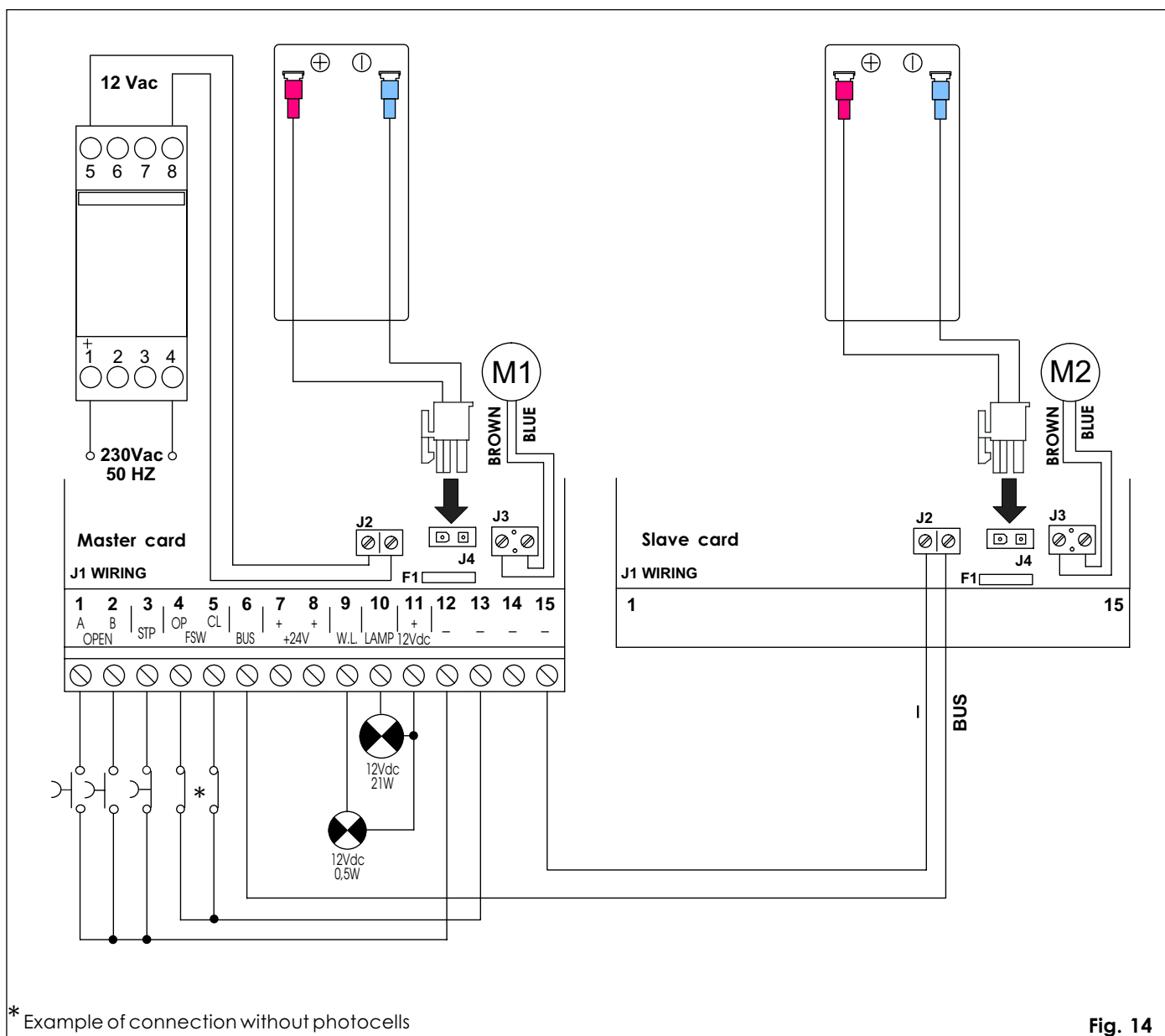

Fig. 14

11.1. Connection of photocells and safety devices

Before connecting the photocells (or other devices) we advise you to select the type of operation according to the movement zone to be protected (see fig.15).

Opening safety devices: they operate only during the gate opening movement and, therefore, they are suitable for protecting the zone between the opening leaves and fixed obstacles (walls, etc) against the risk of impact and crushing.

Closing safety devices: they operate only during the gate closing movement and, therefore, are suitable for protecting the closing zone against the risk of impact.

Opening/closing safety devices: they operate during the gate opening and closing movements and, therefore, they are suitable for protecting the opening and closing zones against the risk of impact.

N.B.: If one or more devices have the same function (opening or closing), they must be connected to each other in series.
N.C. contacts must be used.

Application examples

Commonly used wiring lay-outs:

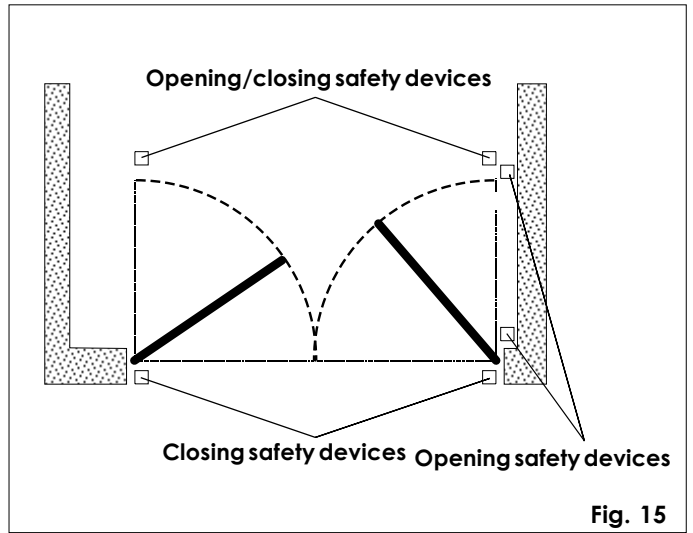

Fig. 15

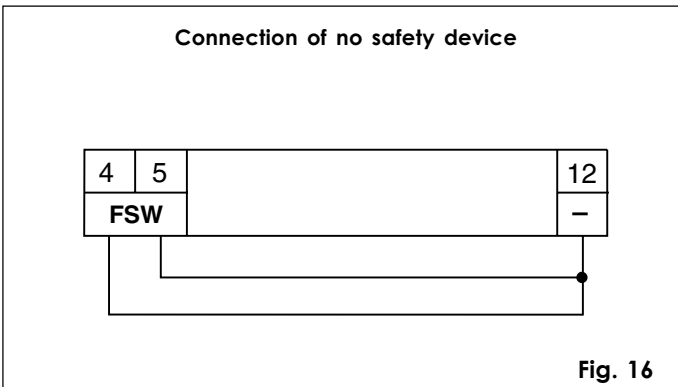

Fig. 16

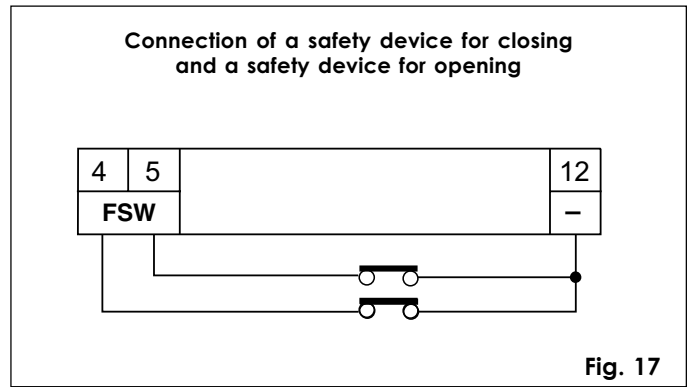

Fig. 17

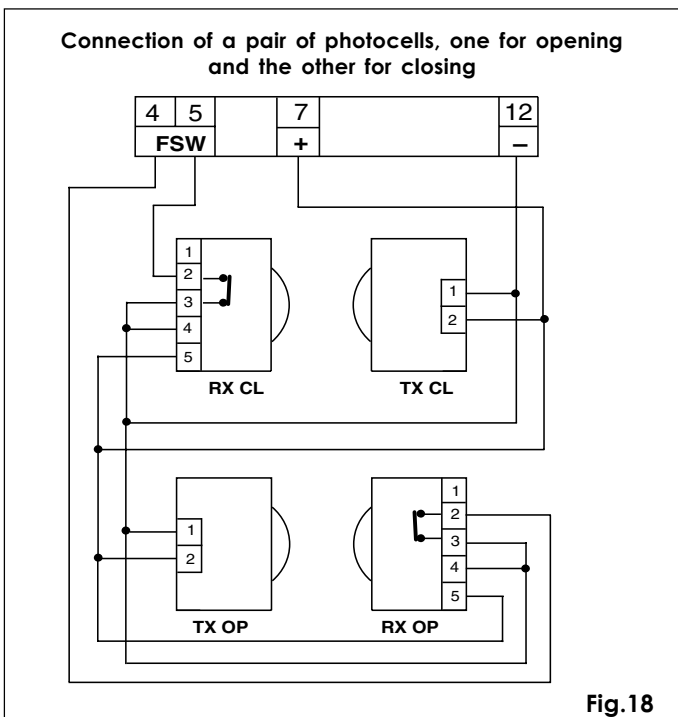

Fig.18

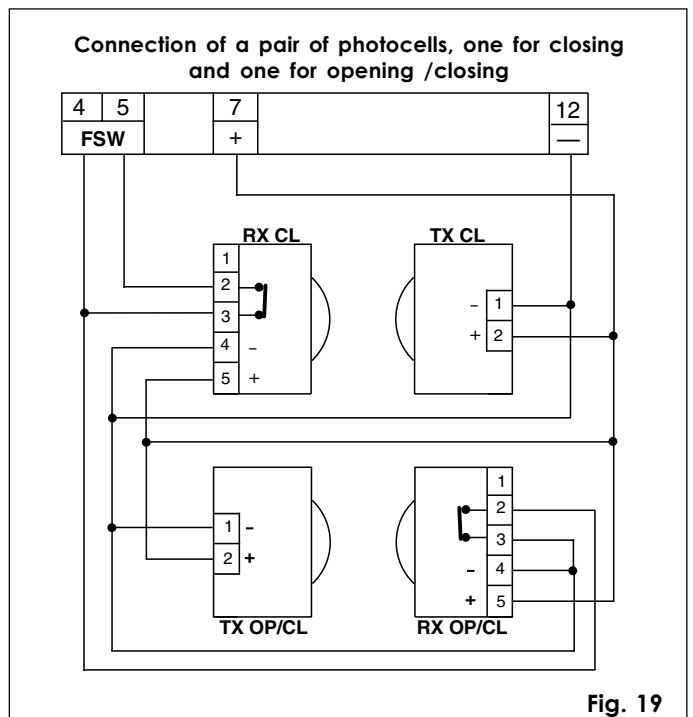
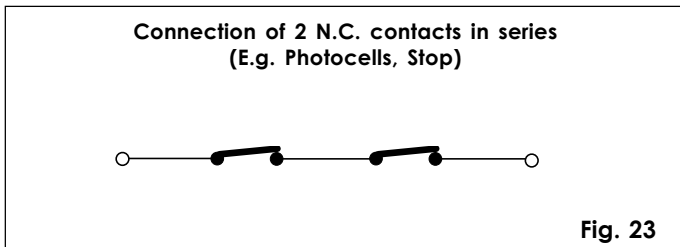
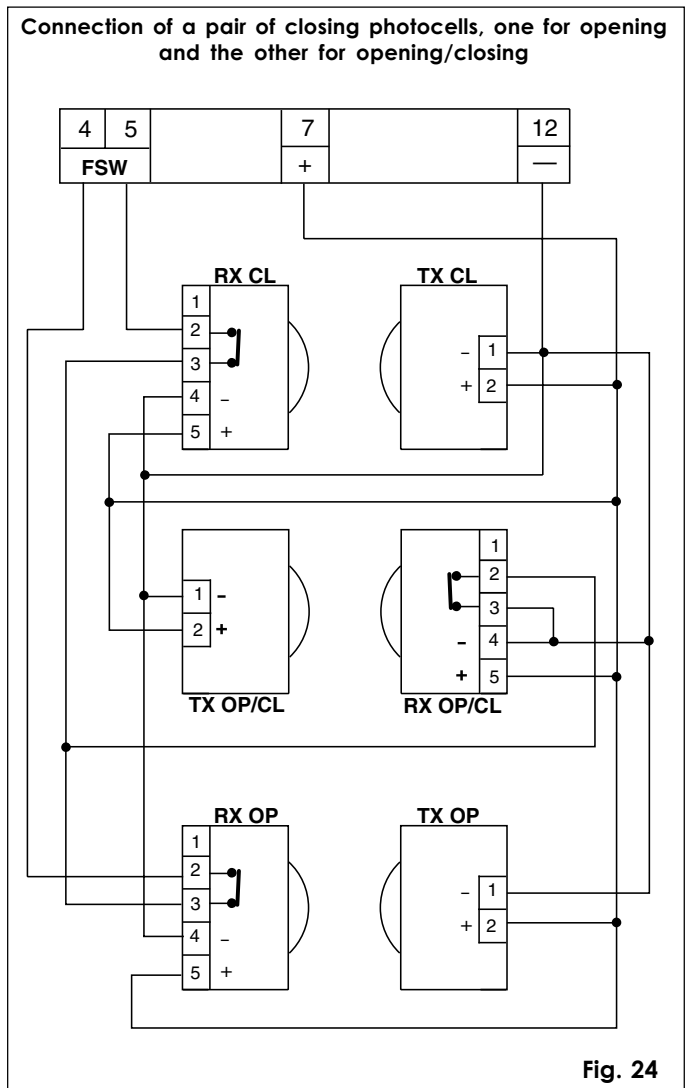
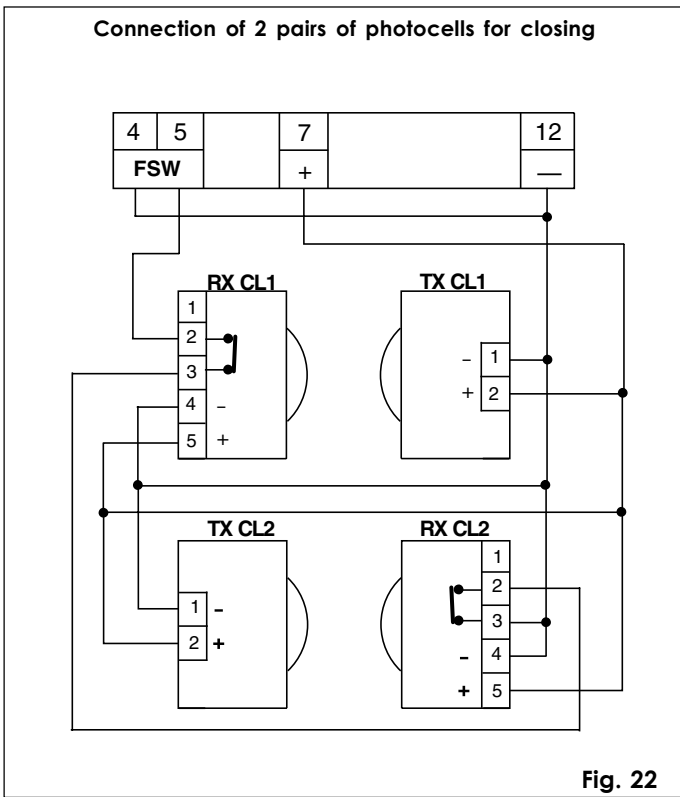
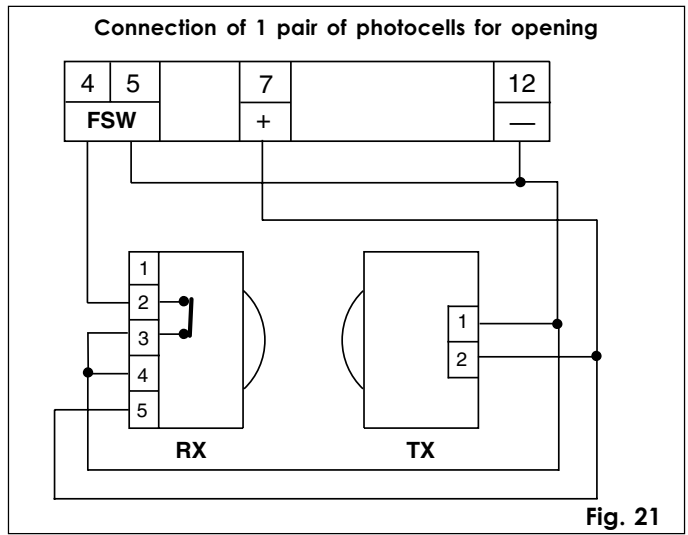
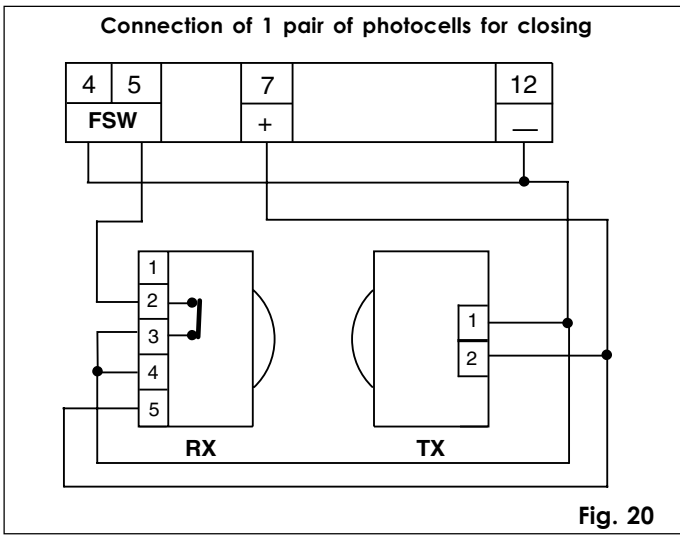

Fig. 19



11.2. J1 TERMINAL BOARD - ACCESSORIES

J1 Terminal board for Master Card - Accessories (fig. 14)
Low voltage terminal board used for connecting all accessories.

24 Vdc

- Negative for powering accessories (terminals 12, 13, 14, 15)
- + Positive for powering accessories + 24 Vdc (terminals 7 and 8)

Important: The maximum load of the accessories powered at

24 Vdc is 150 mA. When the automated system is idle, the accessories are not powered. To calculate absorption values, refer to the instructions for individual accessories.

OPEN A - "TOTAL OPENING" (terminal 1) OPEN command: any device (e.g. push-button) which, by closing a contact, provides an opening and/or closing pulse for both gate leaves.
To install several opening pulse generators, connect the N.O. contacts in parallel (see fig. 25).

OPEN B - "RELEASED LEAF OPENING" (terminal 2) OPEN command: any device (e.g. push-button) which, by closing a contact, provides an opening and/or closing pulse for the gate leaf activated by the Master Card.
To install several opening pulse generators, connect the N.O. contacts in parallel (fig. 25).

STP - STOP Command (terminal 3): any device (e.g.: push-button) which, by opening a contact, stops gate movement.
To install several stop devices, connect the N.C. contacts in series (fig.23).
NB.: If STOP devices are not connected, jumper connect the inputs **STP** and -.

FSW
All devices (photocells, sensitive edges, magnetic loops) with **N.C.** (normally closed) contact, which, if there is an obstacle in the area they protect, operate to interrupt gate leaf movement (fig. 15).

FSW OP. - Opening safety devices contact (terminal 4): during opening, the safety devices reverse motion to closing. They do not operate during closing.
If the **Opening safety devices** are tripped when the gate is closed, they prevent the leaf opening movement.
NB.: If no opening safety devices are connected, jumper connect inputs **OP** and - (fig. 16).
The purpose of the opening safety devices is to safeguard the zone behind the gate leaves (fig. 15).

FSW CL. - Closing safety devices contact (terminal 5): during closing, the safety devices reverse motion to opening. They do not operate during opening.
If the **Closing safety devices** are tripped when the gate is open, they prevent the leaf closing movement.
NB.: If no closing safety devices are connected, jumper connect inputs **CL** and - (fig. 16).
The purpose of the closing safety devices is to safeguard the leaf movement area during closing (fig. 15).

BUS - (terminal 6): Connection between the master and slave equipment. The Bus connection supplies the current for charging the slave card battery and enables communication between the two equipment (terminals 6 and 15 of the master card - connector J2 of the slave card).
To connect, use 2 wires with diameter of 0.5 mm² or greater.

W. LIGHT - (terminals 9 and 11): Power supply for the indicator-light, 12 Vdc 0.5 W max. (terminals 9 and 11). To avoid compromising correct operation of the system, **do not exceed** the indicated power. For instructions on operation of the indicator-light, consult table 3.

LAMP - (terminals 10 and 11): Flashing lamp output, 12 Vdc 21 W. BA15S lamp. To avoid compromising correct operation of the system, **do not exceed** the indicated power.

11.3. J2 Terminal board

It is used for connecting the transformer (optional item), 12 Vac 16 VA. Place the transformer in its compartment, as shown in figure 28, and make the connection as shown in figure 14. Alternatively, the transformer can be remotely located up to a distance of 100 mt from the equipment, using wires with a diameter of 0.5 mm².

11.4. J3 Terminal board - Motor Connection

This terminal board is used for connecting the motor (see fig. 14). For wire colours, refer to fig. 14.

11.5. J4 Connector - Battery connection

Connect the operator support battery (fig. 14) to this connector. The battery is housed as shown in figure 28.

N.B.: The batteries are not supplied fully charged; however, the charge is sufficient for programming and setting-up the system.

11.6. J5 Connector - Quick-fit for Minidec and Rp - 12 Vdc

This is used for rapid connection of the Minidec cards and RP receivers.

IMPORTANT: do not use Decoder cards on the quick-fit connection.

In case of a mains power cut, this connector is powered for twelve hours - after this time, the opening push-buttons (terminals 1 and 2) are the only active commands.

The connector is powered down to store sufficient energy for running some emergency manoeuvres in the space of 30 days.

Tab. 3

| Gate status | Indicator-light status |
|-----------------------------|------------------------|
| Closed | Light Off |
| Open - Open in pause status | Lighted |
| Closing | Flashing |
| Opening | Lighted |
| Blocked | Lighted |

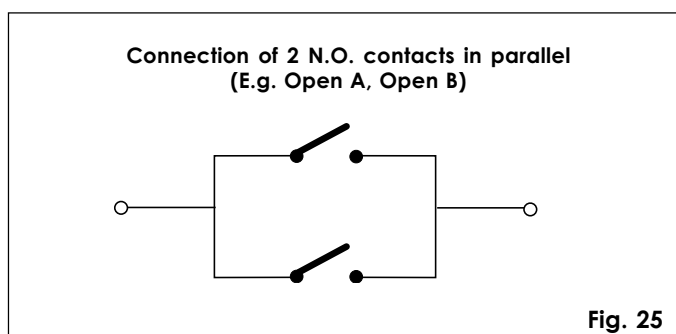

Fig. 25

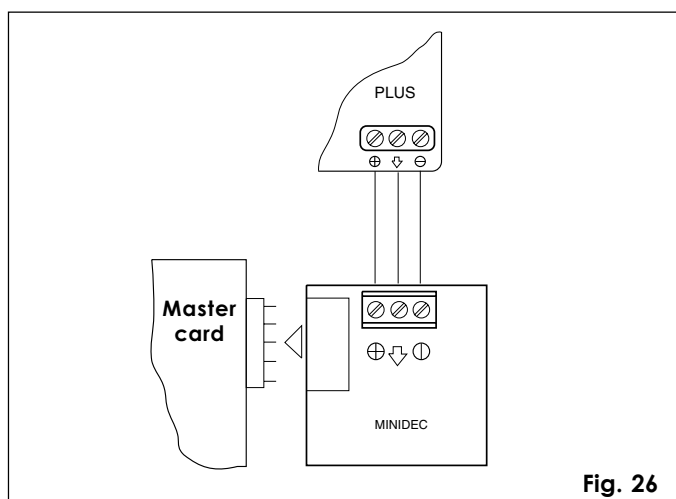

Fig. 26

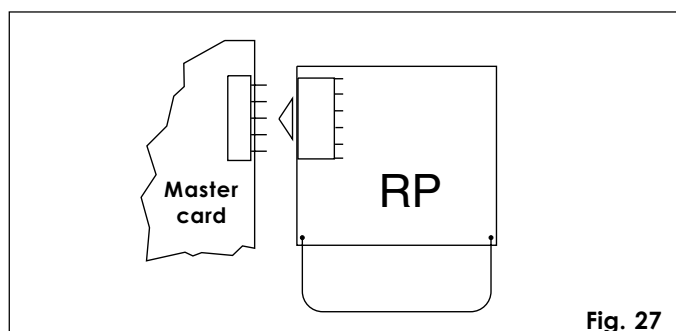

Fig. 27

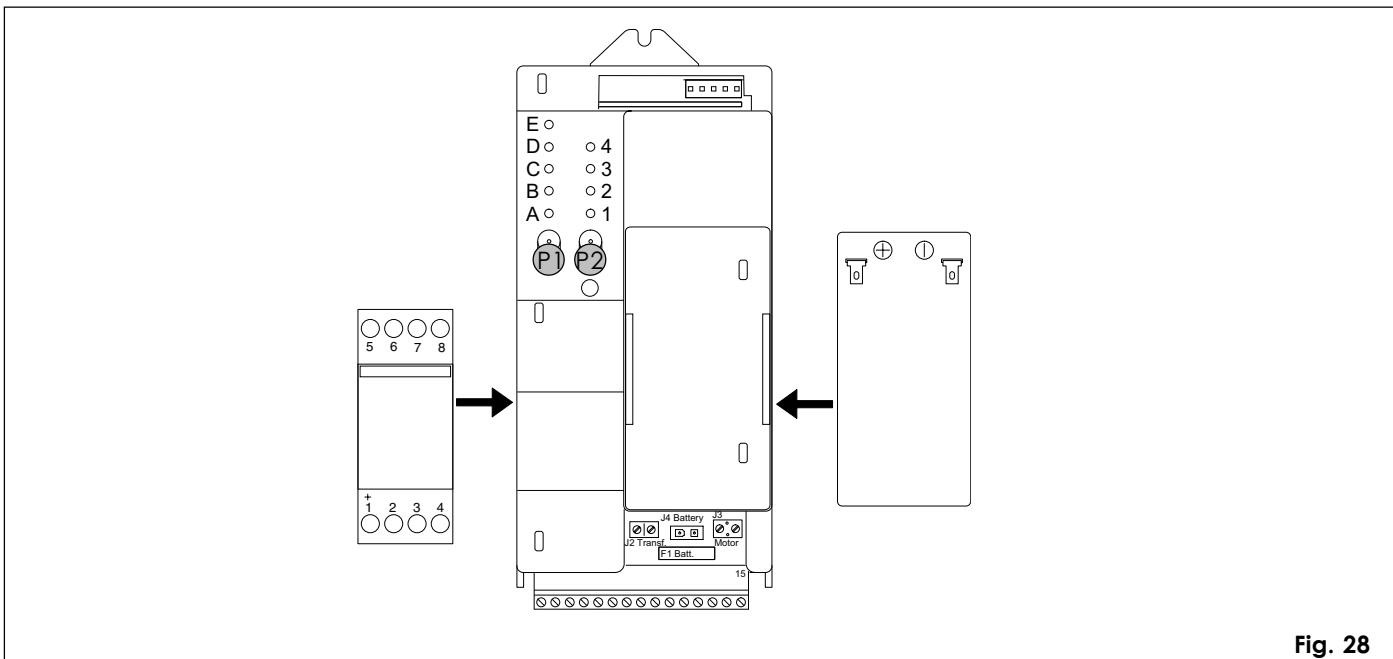

Fig. 28

12. Diagnostics

The "P" LED (see fig. 21) has a diagnostic function. There are 4 LED statuses.

- Steady light indicating mains power ON and battery charged.
- Flashing slowly (lights every second), indicates no mains power but battery charged
- Flashing quickly (lights every 250 msec.) indicates mains power ON but discharged battery
- Light OFF indicates no mains power and discharged battery.

13. Status of inputs

The equipment has a function for checking the status of the inputs on the terminal board.

This is how to access the function:

In the all LEDs OFF status (both LEDs with letters and numbers), press push-button P2 – the status of the inputs will be shown in the LED columns with letters and numbers, as shown in table 4.

Tab.4

| Led | ON | OFF |
|------------|-------------------------|------------------------|
| A = Open A | Command active | Command inactive |
| B = Open B | Command active | Command inactive |
| C = Stop | Command inactive | Command active |
| D = Fsw op | Safety devices disabled | Safety devices enabled |
| E = Fsw cl | Safety devices disabled | Safety devices enabled |

When you have finished checking, press push-button P2 again to exit the inputs status function.

N.B.: The LEDs status check function stays active for 5 minutes and then the board returns to all LEDs OFF status.

WARNING : When you access the inputs status function, all accessories are powered, even with the gate idle. Push-button P1 is active and can be used as Open A.

14. PROGRAMMING

To access the "PROGRAMMING" mode, press push-buttons P1 and P2 (fig. 28). The 5 programming functions are indicated by LEDs with letters, whereas the modifiable values are indicated by numbered LEDs.

Push-button P1 is used to select the function to be programmed.

Push-button P2 is used to modify the value of the selected function.

- If you press push-button P1, LED A lights up; use push-button P2 to select the required logic as shown in table 5.
- If you press push-button P1 again, LED B lights up; use push-button P2 to select the required pause times (for logics A, AP and S only) as shown in table 5.
- If you press push-button P1 again, LED C lights up; use push-button P2 to select the required leaf delays as shown in table 5.
- If you press push-button P1 again, LED D lights up; use push-button P2 to select the static force of the operators as shown in table 5.
- If you press push-button P1 again, LED E lights up; use push-button P2 to select the speed of the operators as shown in table 5.
- If you press push-button P1 again, the five LEDs light up steadily to indicate access to the learning function. There are two learning modes: simple and complete. The travel limit stops are essential for simple learning.

•Simple learning

By using just one command, this procedure enables self-learning of work times and decelerations. Make sure that the leaves are closed.

While the 5 function LEDs are lighted steadily, briefly press (about 1 second) the P2 push-button - the operators start the opening manoeuvre, and the function LEDs begin flashing; Wait for the operators to reach the opening stops. The learning procedure has finished.

•Complete learning

This procedure is used to define the deceleration and stop points of the operators. The procedure differs depending on whether the gate is single leaf or double leaf. Make sure that the leaves are closed.

Procedure for double-leaf gate

While the 5 function LEDs are lighted steadily, hold down push-button P2 for about 3 seconds - operator 1 (master) starts the opening manoeuvre; the following functions are commanded either by open pulses A (e.g. key-operated push-button, radio control) or by the P2 push-button:

- 1st OPEN - Leaf 1 opening deceleration start.
- 2nd OPEN - Leaf 1 opening stop and start of leaf 2 opening movement.

As an alternative to the open, allow the leaf to reach its opening stop point.

3rd OPEN - Leaf 2 opening deceleration start.

4th OPEN - Leaf 2 opening stop and immediate start of leaf 2 closing movement. As an alternative to the open, allow the leaf to reach its opening stop point.

5th OPEN - Leaf 2 closing deceleration stop.

When the leaf has reached its closing stop point, the closing movement of leaf 1 starts immediately.

6th OPEN - Leaf 1 closing deceleration start. Allow the leaf to reach its closing stop point.

The learning procedure has finished.

Procedure for single-leaf gate

While the function 5 LEDs are lighted steadily, hold down push-button P2 for about 3 seconds - operator 1 (master) starts the opening manoeuvre; the following functions are commanded either by open pulses A (e.g. key-operated push-button, radio control) or by the P2 push-button:

1st OPEN - Leaf deceleration start.

2nd OPEN - Leaf opening stop (alternatively, allow the leaf to reach its opening stop point) and immediate closing reverse.

3rd OPEN - Leaf deceleration start. Allow the leaf to reach its closing stop point.

The learning procedure has finished.

Controlling leaf 1 with either Master or Slave card

With this function, you can select the leaf you wish to move with the Master card.

Press and hold down push-button P1, then press push-button P2. LED A starts flashing. Using push-button P2, move from LED 1 to LED2 according to the type of leaf control you require, as described below:

-LED 1 lighted: the Master card commands leaf 1 (Default).

LED 2 lighted: the Master card commands leaf 2.

NOTE: the operation of the Slave card is automatically set, according to how the Master card was programmed.

Table 5

| Programming | |
|-------------|--|
| LED | Function |
| A | Function logic (see tables 6/a, 6/b, 6/c and 6/d) 1 = A (automatic) 2 = S (safety) 3 = AP (stepped automatic) 4 = EP (stepped semi-automatic) (Default) |
| B | Pause times 1 = 5 seconds (Default) 2 = 10 seconds 3 = 20 seconds 4 = 30 seconds |
| C | Opening / Closing delays 1 = op 0 sec./cl 0 sec. 2 = op 2 sec./cl 2 sec. 3 = op 2 sec./cl 4 sec. (Default) 4 = op 2 sec./cl 8 sec. |
| D | Static force 1 = low 2 = medium low 3 = medium high (Default) 4 = high |
| E | Speed 1 = low 2 = medium low (Default) 3 = medium high 4 = high |

15. AUTOMATION TEST

When installation has been completed, run a careful functional check of the automated system and all accessories connected to it, especially the safety devices.

Hand the "User's guide" page to the Customer, and explain correct operation and use of the operator.

16. MANUAL OPERATION

If the gate has to be moved manually due to a fault of the automated system, use the release device as follows:

- Remove the protective cap from the release screw, fit the supplied Allen wrench and turn clockwise until it stops (fig.29).

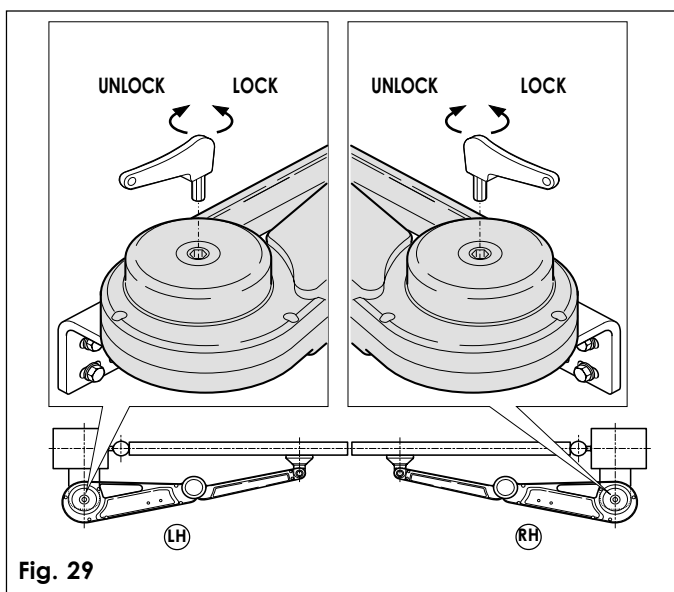

Fig. 29

17. RESTORING NORMAL OPERATION MODE

- Fit the supplied Allen wrench and turn anti-clockwise until it stops (fig.29). Put back the protective cap.

18. MAINTENANCE

Carry out the following jobs at least every six months:

- Check if the anti-crushing device is correctly adjusted.
- Check the efficiency of the release system.
- Check the efficiency of safety devices and accessories.

19. REPAIRS

For any repairs, contact the authorised Repair Centres.

Tab. 6/a

| LOGIC "A" | | | | PULSES | | | |
|---------------|---|--------|------------------------------|---------------------------|--|---------------------------|--|
| GATE STATUS | OPEN-A | OPEN B | STOP | OPENING SAFETY DEVICES | CLOSING SAFETY DEVICES | OP/CLS. SAFETY DEVICE | |
| CLOSED | Opens leaf/ves and re-closes after pause time | | No effect (OPEN disabled) | No effect (OPEN disabled) | No effect | No effect (OPEN disabled) | |
| OPEN on PAUSE | Re-loads pause time | | Stops operation | No effect | Re-loads pause time | | |
| AT CLOSING | Re-opens the leaf/ves immediately | | | No effect | Locks and, on release, reverses at opening | | |
| AT OPENING | No effect | | Inverts movement immediately | No effect | Inverts movement immediately | | |
| LOCKED | Closes the leaf/ves | | No effect | No effect (OPEN disabled) | No effect (OPEN disabled) | | |

Tab. 6/b

| LOGIC "S" | | | | PULSES | | | |
|---------------|---|--------|------------------------------|---------------------------|---------------------------------|------------------------------|--|
| GATE STATUS | OPEN-A | OPEN B | STOP | OPENING SAFETY DEVICES | CLOSING SAFETY DEVICES | OP/CLS. SAFETY DEVICE | |
| CLOSED | Opens leaf/ves and re-closes after pause time | | No effect (OPEN disabled) | No effect (OPEN disabled) | No effect | No effect (OPEN disabled) | |
| OPEN on PAUSE | Re-closes the leaf/ves immediately | | Stops operation | No effect | Closes after 5" (OPEN disabled) | | |
| AT CLOSING | Re-opens the leaf/ves immediately | | | No effect | Inverts movement immediately | Inverts movement immediately | |
| AT OPENING | Re-closes the leaf/ves immediately | | Inverts movement immediately | No effect | Inverts movement immediately | | |
| LOCKED | Closes the leaf/ves | | No effect | No effect (OPEN disabled) | No effect (OPEN disabled) | | |

Tab. 6/c

| LOGIC "AP" | | | | PULSES | | | |
|---------------|---|--------|--|---------------------------|------------------------------|------------------------------|--|
| GATE STATUS | OPEN-A | OPEN B | STOP | OPENING SAFETY DEVICES | CLOSING SAFETY DEVICES | OP/CLS. SAFETY DEVICE | |
| CLOSED | Opens leaf/ves and re-closes after pause time | | No effect (OPEN disabled) | No effect (OPEN disabled) | No effect (OPEN disabled) | No effect (OPEN disabled) | |
| OPEN on PAUSE | Stops operation | | Stops operation | No effect | Re-loads pause time | | |
| AT CLOSING | Re-opens the leaf/ves immediately | | | No effect | Inverts movement immediately | | |
| AT OPENING | Stops operation | | Locks and reverses to close at release | No effect | No effect | Inverts movement immediately | |
| LOCKED | Closes the leaf/ves | | No effect | No effect (OPEN disabled) | No effect (OPEN disabled) | | |

Tab. 6/d

| LOGIC "EP" | | | | PULSES | | | |
|-------------|--------------------------------------|--------|------------------------------|---|------------------------------|------------------------------|--|
| GATE STATUS | OPEN-A | OPEN B | STOP | OPENING SAFETY DEVICES | CLOSING SAFETY DEVICES | OP/CLS. SAFETY DEVICE | |
| CLOSED | Opens leaf/ves | | No effect (OPEN disabled) | No effect (OPEN disabled) | No effect | No effect (OPEN disabled) | |
| OPEN | Re-closes the leaf/ves immediately | | Stops operation | No effect | No effect (OPEN disabled) | | |
| AT CLOSING | Stops operation | | | Inverts movement immediately | Inverts movement immediately | Inverts movement immediately | |
| AT OPENING | Stops operation | | Inverts movement immediately | No effect | No effect | Inverts movement immediately | |
| LOCKED | Restarts moving in reverse direction | | No effect (OPEN disabled) | No effect (if it must open, it disables OPEN) | No effect (OPEN disabled) | No effect (OPEN disabled) | |

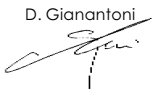
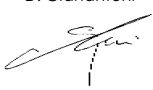
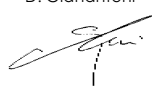
| | | |
|---|---|--|
| <p>DICHIARAZIONE CE DI CONFORMITÀ PER MACCHINE (DIRETTIVA 89/392 CEE, ALLEGATO II, PARTE B)</p> <p>Fabbricante: GENIUS s.r.l. Indirizzo: Via Padre Elzi, 32 24050 - Grassobbio BERGAMO - ITALIA</p> <p>Dichiara che: L'Attuatore mod. FOLD</p> <ul style="list-style-type: none"> è costruito per essere incorporato in una macchina o per essere assemblato con altri macchinari per costituire una macchina ai sensi della Direttiva 89/392/CEE, e successive modifiche 91/368/CEE, 93/44/CEE, 93/68/CEE; è conforme ai requisiti essenziali di sicurezza delle seguenti altre direttive CEE: 73/23/CEE e successiva modifica 93/68/CEE, 89/336 CEE e successiva modifica 92/31/CEE e 93/68/CEE <p>e inoltre dichiara che <u>non è consentito mettere in servizio il macchinario</u> fino a che la macchina in cui sarà incorporata o di cui diverrà componente sia stata identificata e ne sia stata dichiarata la conformità alle condizioni della Direttiva 89/392/CEE e successive modifiche trasposta nella legislazione nazionale dal DPR n° 459 del 24 Luglio 1996.</p> <p>Grassobbio, 1 Marzo 2002</p> <p>L'Amministratore Delegato D. Gianantoni </p> | <p>EC MACHINE DIRECTIVE COMPLIANCE DECLARATION (DIRECTIVE 89/392 EEC, APPENDIX II, PART B)</p> <p>Manufacturer: GENIUS s.r.l. Address: Via Padre Elzi, 32 24050 - Grassobbio BERGAMO - ITALY</p> <p>Hereby declares that: the FOLD</p> <ul style="list-style-type: none"> is intended to be incorporated into machinery, or to be assembled with other machinery to constitute machinery in compliance with the requirements of Directive 89/392 EEC, and subsequent amendments 91/368 EEC, 93/44 EEC and 93/68 EEC; complies with the essential safety requirements in the following EEC Directives: 73/23 EEC and subsequent amendment 93/68 EEC, 89/336 EEC and subsequent amendments 92/31 EEC and 93/68 EEC. <p>and furthermore declares that <u>unit must not be put into service</u> until the machinery into which it is incorporated or of which it is a component has been identified and declared to be in conformity with the provisions of Directive 89/392 EEC and subsequent amendments enacted by the national implementing legislation.</p> <p>Grassobbio, 1 March 2002</p> <p>Managing Director D. Gianantoni </p> | <p>DÉCLARATION CE DE CONFORMITÉ (DIRECTIVE EUROPÉENNE "MACHINES" 89/392/CEE, ANNEXE II, PARTIE B)</p> <p>Fabricant: GENIUS s.r.l. Adresse: Via Padre Elzi, 32 24050 - Grassobbio BERGAMO - ITALIE</p> <p>Déclare d'une part que l'automatisme mod. FOLD</p> <ul style="list-style-type: none"> est prévue soit pour être incorporée dans une machine, soit pour être assemblée avec d'autres composants ou parties en vue de former une machine selon la directive européenne "machines" 89/392 CEE, modifiée 91/368 CEE, 93/44 CEE, 93/68 CEE. satisfait les exigences essentielles de sécurité des directives CEE suivantes: 73/23 CEE, modifiée 93/68 CEE, 89/336 CEE, modifiée 92/31 CEE et 93/68 CEE. <p>et d'autre part qu'il est formellement interdit de mettre en fonction l'automatisme en question avant que la machine dans laquelle il sera intégrée ou dont il constituera un composant ait été identifiée et déclarée conforme aux exigences essentielles de la directive européenne "machines" 89/392/CEE, et décrets de transposition de la directive.</p> <p>Grassobbio, le 1 Mars 2002</p> <p>L'Administrateur Délégué D. Gianantoni </p> |
| <p>DECLARACIÓN DE CONFORMIDAD CE PARA MÁQUINAS (DIRECTIVA 89/392 CEE, ANEXO II, PARTE B)</p> <p>Fabrizante: GENIUS s.r.l. Dirección: Via Padre Elzi, 32 24050 - Grassobbio BERGAMO - ITALIA</p> <p>Declara que: El equipo automático mod. FOLD</p> <ul style="list-style-type: none"> Ha sido construido para ser incorporado en una máquina, o para ser ensamblado con otros mecanismos a fin de constituir una máquina con arreglo a la Directiva 89/392 CEE y a sus sucesivas modificaciones 91/368 CEE, 93/44 CEE y 93/68 CEE. Cumple los requisitos esenciales de seguridad establecidos por las siguientes directivas CEE: 73/23 CEE y sucesiva modificación 93/68 CEE, 89/336 CEE y sucesivas modificaciones 92/31 CEE y 93/68 CEE. <p>Asimismo, declara que <u>no está permitido poner en marcha el equipo</u> si la máquina en la cual será incorporado, o de la cual se convertirá en un componente, no ha sido identificada o no ha sido declarada su conformidad a lo establecido por la Directiva 89/392 CEE y sus sucesivas modificaciones, y a la ley que la incorpora en la legislación nacional.</p> <p>Grassobbio, 1º de Marzo de 2002.</p> <p>Administrador Delegado D. Gianantoni </p> | <p>EG-KONFORMITÄTserklärung zu MASCHINEN (gemäß EG-Richtlinie 89/392/EWG, Anhang II, Teil B)</p> <p>Hersteller: GENIUS s.r.l. Adresse: Via Padre Elzi, 32 24050 - Grassobbio BERGAMO - ITALIEN</p> <p>erklärt hiermit, daß: der Antrieb Mod. FOLD</p> <ul style="list-style-type: none"> zum Einbau in eine Maschine oder mit anderen Maschinen zu einer Maschine im Sinne der Richtlinie 89/392 EWG und deren Änderungen 91/368 EWG, 93/44 EWG, 93/68 EWG vorgesehen ist. den wesentlichen Sicherheitsbestimmungen folgender anderer EG-Richtlinien entspricht: 73/23 EWG und nachträgliche Änderung 93/68 EWG 89/336 EWG und nachträgliche Änderung 92/31 EWG sowie 93/68 EWG <p>und erklärt außerdem, daß die <u>Inbetriebnahme solange untersagt ist</u>, bis die Maschine, in welche diese Maschine eingebaut wird oder von der sie ein Bestandteil ist, den Bestimmungen der Richtlinie 89/392 EWG sowie deren nachträglichen Änderungen entspricht.</p> <p>Grassobbio, 1 März 2002</p> <p>Der Geschäftsführer D. Gianantoni </p> | <p>CE VERKLARING VAN OVEREENSTEMMING VOOR MACHINES (RICHTLIJN 89/392/EEG, BIJLAGE II, DEEL B)</p> <p>Fabrikant: GENIUS s.r.l. Adres: Via Padre Elzi, 32 24050 - Grassobbio BERGAMO - ITALIE</p> <p>verklaart dat: de aandrijving mod. FOLD</p> <ul style="list-style-type: none"> is gebouwd voor opname in een machine of voor assemblage met andere machines, met het doel een machine te vormen in de zin van de Richtlijn 89/392/EEG en latere wijzigingen 91/368/EEG, 93/44/EEG, 93/68/EEG; in overeenstemming is met de fundamentele veiligheidsisen van de volgende EEG-richtlijnen: 73/23/EEG en latere wijziging 93/68/EEG, 89/336/EEG en latere wijziging 92/31/EEG en 93/68/EEG <p>en verklaart bovendien dat het <u>niet is toegestaan de machine in bedrijf te stellen</u> voordat de machine waarin zij wordt opgenomen of waarvan zij onderdeel wordt, geïdentificeerd is, en de overeenkomstigheid ervan verklaard is volgens de voorwaarden van de Richtlijn 89/392/EEG en latere wijzigingen, die in de nationale wetgeving zijn omgezet door het Presidentieel Besluit nr. 459 van 24 juli 1996.</p> <p>Grassobbio, 1 Maart 2002</p> <p>President - directeur D. Gianantoni </p> |

GENIUS®

GENIUS s.r.l.
Via Padre Elzi, 32
24050 - Grassobbio
BERGAMO-ITALY
tel. 0039.035.4242511
fax. 0039.035.4242600
info@geniusg.com
www.geniusg.com

Le descrizioni e le illustrazioni del presente manuale non sono impegnative. GENIUS si riserva il diritto, lasciando inalterate le caratteristiche essenziali dell'apparecchiatura, di apportare in qualunque momento e senza impegnarsi ad aggiornare la presente pubblicazione, le modifiche che essa ritiene convenienti per miglioramenti tecnici o per qualsiasi altra esigenza di carattere costruttivo o commerciale.

The descriptions and illustrations contained in the present manual are not binding. GENIUS reserves the right, while leaving the main features of the equipments unaltered, to undertake any modifications to hold necessary for either technical or commercial reasons, at any time and without revising the present publication.

Les descriptions et les illustrations du présent manuel sont fournies à titre indicatif. GENIUS se réserve le droit d'apporter à tout moment les modifications qu'elle jugera utiles sur ce produit tout en conservant les caractéristiques essentielles, sans devoir pour autant mettre à jour cette publication.

Las descripciones y las ilustraciones de este manual no comportan compromiso alguno. GENIUS se reserva el derecho, dejando inmutadas las características esenciales de los aparatos, de aportar, en cualquier momento y sin comprometerse a poner al día la presente publicación, todas las modificaciones que considere oportunas para el perfeccionamiento técnico o para cualquier otro tipo de exigencia de carácter constructivo o comercial.

Die Beschreibungen und Abbildungen in vorliegendem Handbuch sind unverbindlich. GENIUS behält sich das Recht vor, ohne die wesentlichen Eigenschaften dieses Gerätes zu verändern und ohne Verbindlichkeiten in Bezug auf die Neufassung der vorliegenden Anleitungen, technisch bzw. konstruktiv / kommerziell bedingte Verbesserungen vorzunehmen.

De beschrijvingen en illustraties in deze handleiding zijn niet bindend. GENIUS behoudt zich het recht voor om op elk willekeurig moment, en zonder verplicht te zijn deze publicatie bij te werken, de wijzigingen aan te brengen die wenselijk geacht worden met het oog op technische verbeteringen of om andere redenen van technische of commerciële aard, waarbij de essentiële eigenschappen van de apparatuur ongewijzigd blijven.

Timbro rivenditore:
Distributor's stamp:
Timbre de l'agent:
Sello del revendedor:
Fachhändlerstempel:
Stempel van de dealer:

