

AVVERTENZE PER L'INSTALLATORE

OBBLIGHI GENERALI PER LA SICUREZZA

- 1) ATTENZIONI È importante per la sicurezza delle persone seguire attentamente tutta l'istruzione. Una errata installazione o un errato uso del prodotto può portare a gravi danni alle persone.**
 - 2) Leggere attentamente le istruzioni prima di iniziare l'installazione del prodotto.
 - 3) I materiali dell'imballaggio (plastica, polistirolo, ecc.) non devono essere lasciati alla portata dei bambini in quanto potenziali fonti di pericolo.
 - 4) Conservare le istruzioni per riferimenti futuri.
 - 5) Questo prodotto è stato progettato e costruito esclusivamente per l'utilizzo indicato in questa documentazione. Qualsiasi altro utilizzo non espressamente indicato potrebbe pregiudicare l'integrità del prodotto e/o rappresentare fonte di pericolo.
 - 6) GENIUS declina qualsiasi responsabilità derivata dall'uso improprio o diverso da quello per cui l'automatismo è destinato.
 - 7) Non installare l'apparecchio in atmosfera esplosiva: la presenza di gas o fumi infiammabili costituisce un grave pericolo per la sicurezza.
 - 8) Gli elementi costruttivi meccanici devono essere in accordo con quanto stabilito dalle Norme EN 12604 e EN 12605.
- Per i Paesi extra-CEE, oltre ai riferimenti normativi nazionali, per ottenere un livello di sicurezza adeguato, devono essere seguite le Norme sopra riportate.
- 9) GENIUS non è responsabile dell'inosservanza della Buona Tecnica nella costruzione delle chiusure da motorizzare, nonché delle deformazioni che dovessero intervenire nell'utilizzo.
 - 10) L'installazione deve essere effettuata nell'osservanza delle Norme EN 12453 e EN 12445. Il livello di sicurezza dell'automazione deve essere C+D.
 - 11) Prima di effettuare qualsiasi intervento sull'impianto, togliere l'alimentazione elettrica e scollegare le batterie.
 - 12) Prevedere sulla rete di alimentazione dell'automazione un interruttore onnipolare con distanza d'apertura dei contatti uguale o superiore a 3 mm. È consigliabile l'uso di un magnetotermico da 6A con interruzione anticipata.
 - 13) Verificare che a monte dell'impianto vi sia un interruttore differenziale con soglia da 0,03 A.
 - 14) Verificare che l'impianto di terra sia realizzato a regola d'arte e collegarsi ai parti metalliche della chiusura.
 - 15) L'automazione dispone di una sicurezza intrinseca antischiacciamento costituita da un controllo di coppia. E' comunque necessario verificare la soglia di intervento secondo quanto previsto dalle Norme indicate al punto 10.
 - 16) I dispositivi di sicurezza (norma EN 12978) permettono di proteggere eventuali aree di pericolo da **Rischi meccanici di movimento**, come ad Es. schiacciamento, convogliamento, cesoiamento.
 - 17) Per ogni impianto è consigliato l'utilizzo di almeno una segnalazione luminosa nonché di un cartello di segnalazione fissato adeguatamente sulla struttura dell'infisso, oltre ai dispositivi citati al punto *16*.
 - 18) GENIUS declina ogni responsabilità ai fini della sicurezza e del buon funzionamento dell'automazione, in caso vengano utilizzati componenti dell'impianto non di produzione GENIUS.
 - 19) Per la manutenzione utilizzare esclusivamente parti originali GENIUS.
 - 20) Non eseguire alcuna modifica sui componenti facenti parte del sistema d'automazione.
 - 21) L'installatore deve fornire tutte le informazioni relative al funzionamento manuale del sistema in caso di emergenza e consegnare all'Utente utilizzatore dell'impianto il libretto d'avvertenze allegato al prodotto.
 - 22) Non permettere ai bambini o persone di sostare nelle vicinanze del prodotto durante il funzionamento.
 - 23) Tenere fuori dalla portata dei bambini radiocomandi o qualsiasi altro datore di impulso, per evitare che l'automazione possa essere azionata involontariamente.
 - 24) Il transito tra le ante deve avvenire solo a cancello completamente aperto.
 - 25) L'Utente utilizzatore deve astenersi da qualsiasi tentativo di riparazione o d'intervento diretto e rivolgersi solo a personale qualificato.
 - 26) Tutto quello che non è previsto espressamente in queste istruzioni non è permesso

IMPORTANT NOTICE FOR THE INSTALLER

GENERAL SAFETY REGULATIONS

- 1) ATTENTION! It is important to ensure the safety of people, it is important that you read all the following instructions. Incorrect installation or incorrect use of the product could cause serious harm to people.**
- 2) Carefully read the instructions before beginning to install the product.
- 3) Do not leave packing materials (plastic, polystyrene, etc.) within reach of children as such materials are potential sources of danger.
- 4) Store these instructions for future reference.
- 5) This product was designed and built strictly for the use indicated in this documentation. Any other use, not expressly indicated here, could compromise the good condition/operation of the product and/or be a source of danger.
- 6) GENIUS declines all liability caused by improper use or use other than that for which the automated system was intended.
- 7) Do not install the equipment in an explosive atmosphere: the presence of inflammable gas or fumes is a serious danger to safety.
- 8) The mechanical parts must conform to the provisions of Standards EN 12604 and EN 12605.

For non-EU countries, to obtain an adequate level of safety, the Standards mentioned above must be observed, in addition to national legal regulations.

- 9) GENIUS is not responsible for failure to observe Good Technique in the construction of the closing elements to be motorised, or for any deformation that may occur during use.
- 10) The installation must conform to Standards EN 12453 and EN 12445. The safety level of the automated system must be C+D.
- 11) Before attempting any job on the system, cut out electrical power and disconnect the batteries.
- 12) The mains power supply of the automated system must be fitted with an all-pole switch with contact opening distance of 3mm or greater. Use of a 6A thermal breaker with all-pole circuit break is recommended.
- 13) Make sure that a differential switch with threshold of 0.03 A is fitted upstream of the system.
- 14) Make sure that the earthing system is perfectly constructed, and connect metal parts of the means of the closure to it.
- 15) The automated system is supplied with an intrinsic anti-crushing safety device consisting of a torque control. Nevertheless, its tripping threshold must be checked as specified in the Standards indicated at point 10.
- 16) The safety devices (EN 12978 standard) protect any danger areas against **mechanical movement Risks**, such as crushing, dragging, and shearing.
- 17) Use of at least one indicator-light is recommended for every system, as well as a warning sign adequately secured to the frame structure, in addition to the devices mentioned at point *16*.
- 18) GENIUS declines all liability as concerns safety and efficient operation of the automated system, if system components not produced by GENIUS are used.
- 19) For maintenance, strictly use original parts by GENIUS.
- 20) Do not in any way modify the components of the automated system.
- 21) The installer shall supply all information concerning manual operation of the system in case of an emergency, and shall hand over to the user the warnings handbook supplied with the product.
- 22) Do not allow children or adults to stay near the product while it is operating.
- 23) Keep remote controls or other pulse generators away from children, to prevent the automated system from being activated involuntarily.
- 24) Transit through the leaves is allowed only when the gate is fully open.
- 25) The user must not attempt any kind of repair or direct action whatever and contact qualified personnel only.
- 26) Anything not expressly specified in these instructions is not permitted.

CONSIGNES POUR L'INSTALLATEUR

RÈGLES DE SÉCURITÉ

- 1) ATTENTION! Il est important, pour la sécurité des personnes, de suivre à la lettre toutes les instructions. Une installation erronée ou un usage erroné du produit peut entraîner de graves conséquences pour les personnes.**
 - 2) Lire attentivement les instructions avant d'installer le produit.
 - 3) Les matériaux d'emballage (matière plastique, polystyrène, etc.) ne doivent pas être laissés à la portée des enfants car ils constituent des sources potentielles de danger.
 - 4) Conserver les instructions pour les références futures.
 - 5) Ce produit a été conçu et construit exclusivement pour l'usage indiqué dans cette documentation. Toute autre utilisation non expressément indiquée pourrait compromettre l'intégrité du produit et/ou représenter une source de danger.
 - 6) GENIUS décline toute responsabilité qui dériverait d'un usage impropre ou différent de celui auquel l'automatisme est destiné.
 - 7) Ne pas installer l'appareil dans une atmosphère explosive: la présence de gaz ou de fumées inflammables constitue un grave danger pour la sécurité.
 - 8) Les composants mécaniques doivent répondre aux prescriptions des Normes EN 12604 et EN 12605.
- Pour les Pays extra-CEE, l'obtention d'un niveau de sécurité approprié exige non seulement le respect des normes nationales, mais également le respect des Normes susmentionnées.
- 9) GENIUS n'est pas responsable du non-respect de la Bonne Technique dans la construction des fermetures à motoriser, ni des déformations qui pourraient intervenir lors de l'utilisation.
 - 10) L'installation doit être effectuée conformément aux Normes EN 12453 et EN 12445. Le niveau de sécurité de l'automatisme doit être C+D.
 - 11) Couper l'alimentation électrique et déconnecter la batterie avant toute intervention sur l'installation.
 - 12) Prévoir, sur le secteur d'alimentation de l'automatisme, un interrupteur onnipolaire avec une distance d'ouverture des contacts égale ou supérieure à 3 mm. On recommande d'utiliser un magnétothermique de 6A avec interruption onnipolaire.
 - 13) Vérifier qu'il y ait, en amont de l'installation, un interrupteur différentiel avec un seuil de 0,03 A.
 - 14) Vérifier que la mise à terre est réalisée selon les règles de l'art et y connecter les pièces métalliques de la fermeture.
 - 15) L'automatisme dispose d'une sécurité intrinsèque anti-écrasement, formée d'un contrôle du couple. Il est toutefois nécessaire d'en vérifier le seuil d'intervention suivant les prescriptions des Normes indiquées au point 10.
 - 16) Les dispositifs de sécurité (norme EN 12978) permettant de protéger des zones éventuellement dangereuses contre les **Risques mécaniques du mouvement**, comme l'écrasement, l'achèvement, le cisaillement.

CONTENTS

CE DECLARATION OF CONFORMITY	pag.8
GENERAL CHARACTERISTICS	pag.9
TECHNICAL SPECIFICATIONS	pag.9
BOARD LAY-OUT	pag.9
PREPARATIONS	pag.10
CONNECTIONS AND OPERATION	pag.10
INSTALLING THE RADIO CONTROL RECEIVER BOARD	pag.11
ADJUSTING THE OPERATING PARAMETERS	pag.12
ENCODER OPERATION	pag.12
ADJUSTING MOTOR POWER	pag.12
CONNECTION LAY-OUT	pag.13
CONTROL LEDES	pag.13
FUNCTION LOGICS	pag.14

CE DECLARATION OF CONFORMITY

Manufacturer: GENIUS S.p.A.

Address: Via Padre Elzi, 32 - 24050 - Grassobbio- Bergamo - ITALY

Declares that: Equipment mod. **SPRINT 05**

- conforms to the essential safety requirements of the following EEC directives:
73/23/EEC and subsequent modification 93/68/EEC.
89/336/EEC and subsequent modification 92/31/EEC and 93/68/EEC

Additional note:

This product was tested in a typical, uniform configuration (all products made by GENIUS S.r.l.)

Grassobbio, 01 June 2005

Managing Director
D. Giandonni



SPRINT 05 CONTROL UNIT FOR 230V SLIDING GATES

1. GENERAL CHARACTERISTICS

The **SPRINT 05** control unit was designed to control sliding operators with maximum power of 600W. Thanks to its active and passive security controls, if correctly installed, it guarantees installation complying with the current safety regulations. The possibility of also controlling an encoder further increases the level of safety.

Very simple programming of the main functions cuts down installation time.

With its five built-in LEDs, it provides information at all times about the state of safety devices and limit-switches.

2. TECHNICAL SPECIFICATIONS

Power supply	230V~ (+6% -10%) 50Hz
Absorbed power	15 W
Motor max. load	600 W
Accessories max. load	500 mA
Operating ambient temperature	-20°C +55°C
Protection fuses	2
Function logics	Automatic / Manual
Opening / closing time	120 sec.
Pause time	Four preset levels
Motor power	Trimmer-adjustable
Terminal board inputs	Open A / Open B / Stop / Opening limit-switch / Closing limit-switch / Photocells / Power supply
Terminal board outputs	24Vdc accessories power supply / Flashing lamp / Motor
Rapid connector	Connector for 5-pin receiver / Encoder
Programmable functions	Function logic / Pause time / Clutch sensitivity / Operation with encoder / Safety devices logic / Condo function
Dimensions	145 x 105

3. BOARD LAY-OUT

CN1	Encoder connector
CN2	Low voltage terminal board
CN3	High voltage terminal board
CN4	Receiver connector
TR1	Motor power adjustment trimmer
DP1	Parameter adjustment Dip-switch
F1	Power fuse / motor 3.15A T (5x20)
F2	Fuse for accessories 0.5A T (5x20)
LED	Safety devices status LED

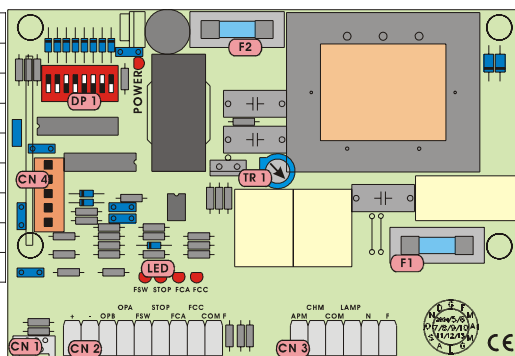

Fig. 1

4. PREPARATIONS

ATTENTION: To ensure people's safety, all warnings and instructions in this booklet must be carefully observed. Incorrect installation or incorrect use of the product could cause serious harm to people.

- Make sure there is an adequate differential switch upstream of the system as specified by current laws, and install a single-pole thermal breaker on the electric power mains.
- Make sure that an adequate earthing system is available.
- To lay cables, use adequate rigid and/or flexible tubes.
- Always separate 230V - power cables from low voltage control cables. To avoid any interference, use separate sheaths.

5. CONNECTIONS AND OPERATION

5.1. CN1 CONNECTOR

The encoder, if supplied, should be connected to this connector. For encoder operation, consult paragraph 7.

5.2. TERMINAL BOARD CN2

5.2.1. 24 Vdc accessories power supply

Terminals "+ & -". The accessories 24 Vdc power cables should be connected to these terminals.

Attention:

- **The maximum load of the accessories must not exceed 500 mA.**
- **The output of these terminals is DC - observe the power supply polarity of the accessories.**

5.2.2. Open A

Terminals "OPA & -". Normally open contact. Connect, to these terminals, any pulse generator (e.g. push-button, key selector, etc..) which, by closing the contact, commands the gate to totally open or close. The operation of this contact is defined by dip-switch 4 (see paragraph 8).

Attention:

- **A total opening pulse always has priority over partial opening.**
- **To connect several pulse generators, connect the devices in parallel.**

5.2.3. Open B

Terminals "OPB & -". Normally open contact. Connect, to these terminals, any pulse generator (e.g. push-button, key selector, etc..) which, by closing the contact, commands the gate to partially open (opens for 8 seconds).

Attention:

- **A total opening pulse always has priority over partial opening.**
- **To connect several pulse generators, connect the devices in parallel.**

5.2.4. Photocells

Terminals "FSW & -". Normally closed contact. The photocells should be connected to these terminals. The photocells can operate both as closing safety devices and as opening and closing safety devices. Operation is defined by dip-switch 5 (see paragraph 8). The status of this input is signalled by LED "FSW".

Attention: Do not connect other safety devices (i.e. apart from photocells) to these terminals.

5.2.5. Stop

Terminals "STOP & -". Normally closed contact. Connect, to these terminals, any safety device (push-button, key selector, etc.) that must stop gate movement, disabling any automatic functions. The gate resumes its memory-stored cycle only by means of another total opening pulse. The status of this input is signalled by the "STOP" LED.

Attention:

- **To connect several pulse generators, connect the devices in series.**

5.2.6. Opening limit switch

Terminals "FCA & COMF". Normally closed contact. It stops the gate opening movement. The status of this input is signalled by LED "FCA".

5.2.7. Closing limit switch.

Terminals "FCC & COMF". Normally closed contact. It stops the gate closing movement. The status of this input is signalled by LED "FCC".

Attention:

- Both limit-switches must be connected to ensure correct operation of the automated system.
- The COMF terminal must be used **ONLY FOR** connecting the common contact of the limit-switches.

The magnetic sensor supplied with the operator is designed for rapid connection to the control unit (Fig.2). To use the sensor with this equipment, cut the connecting terminal from the sensor cable and connect the wires on the terminal-board as indicated in paragraph 11. To connect the wires, follow the instructions in Fig.3.

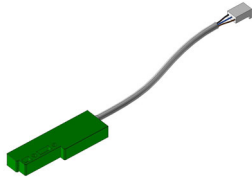

Fig. 2

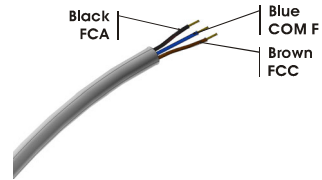

Fig. 3

5.3. TERMINAL BOARD CN3

5.3.1. Gearmotor

Terminals "APM - CHM - COM" (opens - closes - common). Connect the gearmotor power cables to these terminals, connecting the capacitor between terminals APM and CHM.

5.3.2. Flashing lamp

Terminals "LAMP & N". Connect the flashing lamp to these terminals. Output of these terminals is 230V~.

Attention: The flashing is not commanded by the control unit but by the flashing lamp.

5.3.3. Power line

Terminals "N & F". Connect power supply line 230V~ 50Hz to these terminals.

6. INSTALLING THE RADIO CONTROL RECEIVER BOARD

The control unit is designed to house a 5-pin radio-receiver module. Installation procedure: turn off power and fit the module on connector **CN4** (see Fig.1) on the control unit.

Attention: To avoid damaging the receiver and thus irreparably compromising its operation, the receiver must be installed, observing the fitting direction specified in Fig.4.

Then, follows the radio-receiver instructions for memory-storing the radio control.

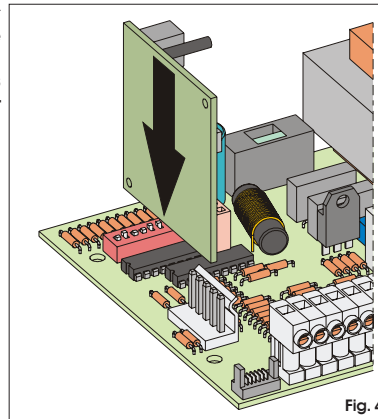
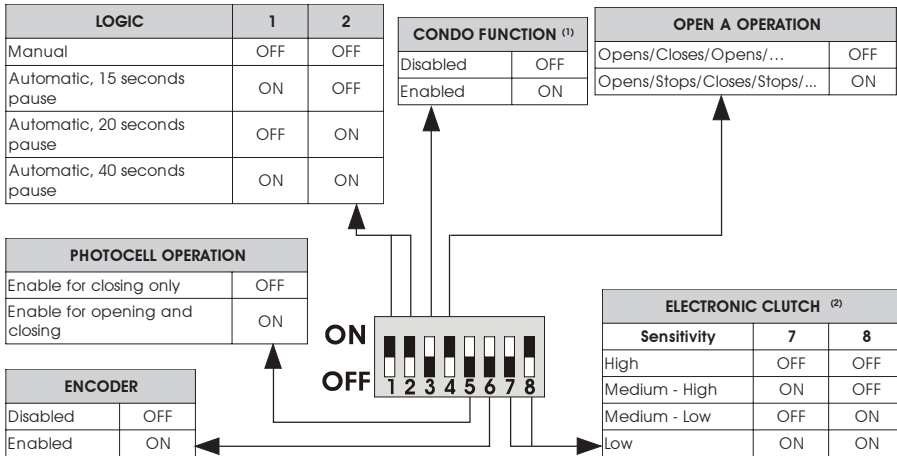

Fig. 4

7. ADJUSTING THE OPERATING PARAMETERS

All the board's programmable functions are defined by using dip-switch **DP1** (see Fig.1). The various options are listed in the following tables.



⁽¹⁾ When the condo function is enabled, the control unit ignores the Open pulses during opening motion.

⁽²⁾ Adjustment of the electronic clutch with the Dip-switches is enabled only if the encoder is used (See parag. 9).

Attention: Use the dip-switches, only after cutting power. Otherwise, operation of the control unit would be at risk.

8. ENCODER OPERATION

The control unit is designed for connection to an Encoder (optional item), which guarantees a higher level of safety. During operation, motor power is directly controlled by the encoder, which detects any obstacles as the gate moves. If obstacles are encountered, the encoder reverses gate movement for two seconds without disabling any automatic closing, if enabled. The encoder puts the control unit in STOP state only if it is tripped twice consecutively. It disables any automatic closure request, because if the encoder intervenes several times, this means that the obstacle is still there and any automatic devices could be a source of danger. When the control unit is in STOP state, an OPEN A or B pulse must be supplied to resume normal operation. Encoder tripping sensitivity is adjusted by dip-switches 7-8 (see parag.7).

Attention: Use of the encoder does not replace the limit-switches, which are compulsory.

9. ADJUSTING MOTOR POWER

Motor power is adjusted in two different ways, according to whether an encoder is connected or not.

➤ **Without encoder:** to adjust motor power, use trimmer TR1 (see Fig.1), turning it anti-clockwise to reduce power and clockwise to increase it. Motor power must be adjusted according to gate dimensions, weight, and to gate friction during movement.

➤ **With encoder:** Motor power is controlled directly by the encoder. To adjust encoder sensitivity, use dip-switches 7 and 8 as specified in parag.7.

11. CONNECTION LAY-OUT

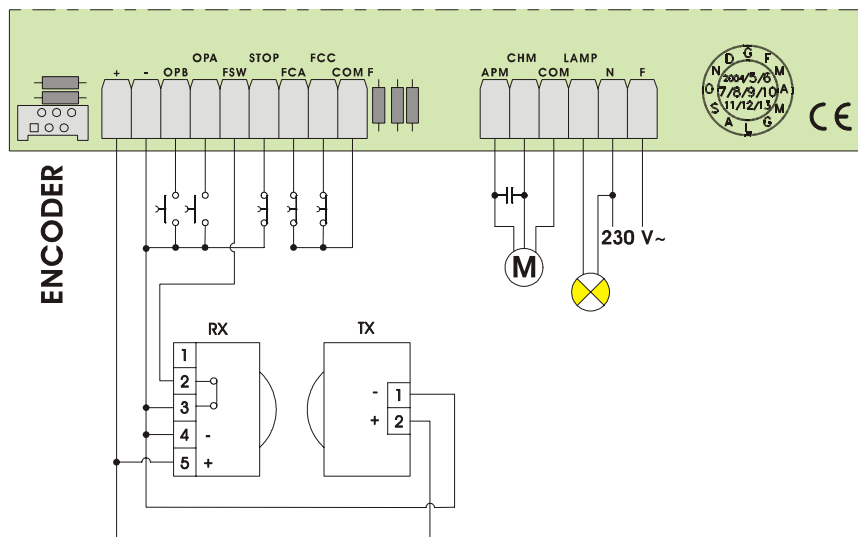

Fig. 5

12. CONTROL LEDES

LEDs	LIGHTED	OFF
POWER	Control unit powered	Control unit not powered
FSW	Safety devices not tripped	Safety devices tripped
STOP	Command not enabled	Command enabled
FCA	Opening limit switch free	Opening limit switch engaged
FCC	Closing limit switch free	Closing limit switch engaged

⇒ Status of LEDs, with powered control unit and gate at rest shown in bold.

13. FUNCTION LOGICS

Automatic logic

Pulses

Gate status	Open A	Open B	Stop	Closing safety devices	Opening / closing safety devices
Closed	Opens gate and closes after pause time	Opens for 8 seconds and closes after pause time	If active, it disables the Open commands	If active, it disables the Open commands	If active, it disables the Open commands
Open on pause	Closes immediately	Closes immediately	Stops operation (2)	Recharges pause time (3)	Recharges pause time (3)
Closing	Stops movement / reverses (1)	No effect	Stops operation (2)	Reverses gate movement	Stops operation and reverses motion on release
Opening	Stops movement / reverses (1)	Reverses gate movement	Stops operation (2)	No effect	Stops operation and restarts on release

Manual logic

Pulses

Gate status	Open A	Open B	Stop	Closing safety devices	Opening / closing safety devices
Closed	Opens	Opens for 8 seconds	If active, it disables the Open commands	If active, it disables the Open commands	If active, it disables the Open commands
Open	Closes	Closes	If active, it disables the Open commands	If active, it disables the Open commands	If active, it disables the Open commands
Closing	Stops movement / reverses (1)	No effect	Stops operation (2)	Reverses gate movement	Stops operation and reverses motion on release
Opening	Stops movement / reverses (1)	Reverses gate movement	Stops operation (2)	No effect	Stops operation and restarts on release

(1) The behaviour of Open A push-button is defined by Dip-switch 4 - see parag.7.

(2) The Stop pulse stops gate operation and disables all selected automatic functions. An Open A pulse is necessary to resume the memory-stored cycle.

(3) If the safety device is engaged when the programmed pause time elapses, when it is released, the control unit resumes counting the programmed pause time.

Le descrizioni e le illustrazioni del presente manuale non sono impegnative. GENIUS si riserva il diritto, lasciando inalterate le caratteristiche essenziali dell'apparecchiatura, di apportare in qualunque momento e senza impegnarsi ad aggiornare la presente pubblicazione, le modifiche che essa ritiene convenienti per miglioramenti tecnici o per qualsiasi altra esigenza di carattere costruttivo o commerciale.

The descriptions and illustrations contained in the present manual are not binding. GENIUS reserves the right, whilst leaving the main features of the equipments unaltered, to undertake any modifications to holds necessary for either technical or commercial reasons, at any time and without revising the present publication.

Les descriptions et les illustrations du présent manuel sont fournies à titre indicatif. GENIUS se réserve le droit d'apporter à tout moment les modifications qu'elle jugera utiles sur ce produit tout en conservant les caractéristiques essentielles, sans devoir pour autant mettre à jour cette publication .

Las descripciones y las ilustraciones de este manual no comportan compromiso alguno. GENIUS se reserva el derecho, dejando inmutadas las características esenciales de los aparatos, de aportar, en cualquier momento y sin comprometerse a poner al día la presente publicación, todas las modificaciones que considere oportunas para el perfeccionamiento técnico o para cualquier otro tipo de exigencia de carácter constructivo o comercial.

Die Beschreibungen und Abbildungen in vorliegendem Handbuch sind unverbindlich. GENIUS behält sich das Recht vor, ohne die wesentlichen Eigenschaften dieses Gerätes zu verändern und ohne Verbindlichkeiten in Bezug auf die Neufassung der vorliegenden Anleitungen, technisch bzw. konstruktiv / kommerziell bedingte Verbesserungen vorzunehmen.

Timbro rivenditore: / Distributor's stamp: / Timbre de l'agent: /
Sello del revendedor: / Fachhändlerstempel:

GENIUS S.p.A.

Via Padre Elzi, 32
24050 - Grassobbio
BERGAMO-ITALY
tel. 0039.035.4242511
fax. 0039.035.4242600
info@geniusg.com
www.geniusg.com

